

Axial piston variable pump A10VG Series 10



- ▶ Medium pressure pump for closed-circuit applications
- ▶ Size 18 ... 63
- ▶ Nominal pressure 300 bar
- ▶ Maximum pressure 350 bar
- ▶ Closed circuit

Features

- ▶ Integrated boost pump for boost and pilot oil supply
- ▶ Flow direction changes when the swashplate is moved through the neutral position
- ▶ High-pressure relief valves with integrated boost function
- ▶ Boost-pressure relief valve
- ▶ Optional with pressure cut-off
- ▶ Large variety of controls
- ▶ Swashplate design

Contents

Type code	2
Hydraulic fluids	5
Working pressure range	6
Technical data	8
HD – Proportional control, hydr., pilot-pressure related	10
HW – Proportional control, hydr., mechanical servo	12
DA – Automatic control, speed related	14
DG – Hydraulic control, direct operated	17
EP – Proportional control, electric	18
EZ – Two-point control, electric	20
ET – Electric control, direct operated	21
ED – Electric pressure control	22
Dimensions, size 18	24
Dimensions, size 28	27
Dimensions, size 45	32
Dimensions, size 63	37
Dimensions, through drive	41
Overview of mounting options	44
Combination pumps A10VG + A10VG	45
High-pressure relief valves	46
Pressure cut-off	47
Mechanical stroke limiter	48
Stroking chamber pressure port X ₃ and X ₄	49
Measuring ports M _A , M _B , M _H	50
Filtration in the boost pump suction line	51
Filtration in the boost pump pressure line	51
External boost pressure supply	52
Connector for solenoids	53
Rotary inch valve	54
Installation dimensions for coupling assembly	55
Installation instructions	56
Project planning notes	59
Safety instructions	60

Type code

01	02	03	04	05	06	07	08	09	10	11	12	13	14	15	16	17	18	19	20	21	22	
A10V	G								/	10		-	N		C							

Axial piston unit

01	Swashplate design, variable, nominal pressure 300 bar, maximum pressure 350 bar	A10V
----	---	-------------

Operating mode

02	Pump, closed circuit	G
----	----------------------	----------

Size (NG)

03	Geometric displacement, see "Technical data" on page 8	18	28	45	63
----	--	-----------	-----------	-----------	-----------

Control device

		18	28	45	63				
04	Proportional control hydraulic	pilot-pressure related, with inlet filtration in P and X₁/X₂		•	•	•	•	HD3	
		mechanical servo		•	•	•	•	HW	
	Automatic control, speed related ¹⁾		<i>U</i> = 12 V		-	•	•	•	DA1
			<i>U</i> = 24 V		-	•	•	•	DA2
	Hydraulic control	direct operated		•	•	•	•	DG	
	Proportional control, electric	with proportional solenoid with inlet filtration in P and X₁/X₂	<i>U</i> = 12 V		•	•	•	•	EP3
			<i>U</i> = 24 V		•	•	•	•	EP4
	Two-point control, electric	with switching solenoid	<i>U</i> = 12 V		•	•	•	•	EZ1
			<i>U</i> = 24 V		•	•	•	•	EZ2
	Electric control, direct operated	two pressure reducing valves (FTDRE)	<i>U</i> = 12 V		-	•	•	-	ET3
<i>U</i> = 24 V			-	•	•	-	ET4		
Electric pressure controller, negative control, with 4/2 directional valve and one pressure reducing valve ¹⁾	de-energized, stroking chamber is controlled via X₁	<i>U</i> = 24 V		-	•	•	•	ED2	
	de-energized, stroking chamber is controlled via X₂	<i>U</i> = 24 V		-	•	•	•	ED4	

Pressure cut-off

		18	28	45	63	
05	Without pressure cut-off (without symbol)	•	•	•	•	
	With pressure cut-off	-	•	•	•	D

Neutral position switch

		18	28	45	63	
06	Without neutral position switch (without symbol)	•	•	•	•	
	Neutral position switch with DEUTSCH connector (only for HW control)	•	•	•	•	L

Mechanical stroke limiter²⁾

		18	28	45	63	
07	Without mechanical stroke limiter (without symbol)	•	•	•	•	
	Mechanical stroke limiter, externally adjustable	•	•	•	•	M

Stroking chamber pressure port²⁾

		18	28	45	63	
08	Without stroking chamber pressure port X₃ , X₄ (without symbol)	•	•	•	•	
	Stroking chamber pressure port X₃ , X₄	-	•	•	•	T

• = Available ◦ = On request - = Not available = Preferred program

1) Only possible in combination with pressure cut-off (DA.D..., ED.D...)

2) Not available in combination with DG control device

01	02	03	04	05	06	07	08	09	10	11	12	13	14	15	16	17	18	19	20	21	22	
A10V	G								/	10		-	N		C							

DA control valve for NG28 ... 63		HD	HW	DG	DA	EP	EZ	ET	ED	
09	Without DA control valve	●	●	●	-	●	●	●	●	1
	DA control valve, fixed setting	●	●	●	●	●	-	-	-	2
	DA control valve, mechanically adjustable, direction of actuation, counter-clockwise with position lever	●	●	●	●	●	-	-	-	3L
	DA control valve, mechanically adjustable, direction of actuation, clockwise with position lever	●	●	●	●	●	-	-	-	3R
	DA control valve, fixed setting, ports for pilot control device	●	●	-	●	●	-	-	-	7
	DA control valve, fixed setting, and hydraulic inch valve mounted, control with mineral oil	-	-	-	●	-	-	-	-	8

Series										
10	Series 1, index 0									10

Direction of rotation		18	28	45	63					
11	Viewed on drive shaft	clockwise				●	●	●	●	R
		counter-clockwise				●	●	●	●	L

Sealing material		18	28	45	63	
12	NBR (nitrile rubber), shaft seal made of FKM (fluoroelastomer)	●	●	●	●	N

Drive shaft		18	28	45	63	
13	Splined shaft for single pump	●	●	●	●	S
	ANSI B92.1a-1976 for combination pump	-	●	●	●	T

Mounting flange		18	28	45	63	
14	SAE J744 2-hole	●	●	●	●	C

Working port		18	28	45	63	
15	Port thread: Metric with profile sealing ring sealing according to DIN 3852					
	Fastening thread at the SAE working port and through drive: Metric according to DIN 13					
	SAE working port A and B , same side left suction port S bottom	-	●	●	●	10
	SAE working port A and B , same side right suction port S at top (externally piped up, except for DG)	-	●	●	●	13
	Port and working port thread: Metric with profile sealing ring sealing according to DIN 3852					
	Fastening thread at the through drive: Metric according to DIN 13					
	Threaded port A and B , same side right suction port S bottom	●	-	-	-	16

Boost pump		18	28	45	63	
16	Without integrated boost pump					
	without through drive	●	●	●	●	N
	with through drive	●	●	●	●	K
	Integrated boost pump					
	with and without through drive	●	●	●	●	F

● = Available ○ = On request - = Not available = Preferred program

4 **A10VG Series 10** | Axial piston variable pump
Type code

01	02	03	04	05	06	07	08	09	10	11	12	13	14	15	16	17	18	19	20	21	22	
A10V	G								/	10		-	N		C							

Through drive³⁾ **18 28 45 63**

17	Without through drive, only for version N and F (position 16)											•	•	•	•	00
	Flange SAE J744		Hub for splined shaft ⁴⁾													
	82-2 (A)		5/8 in	9T 16/32DP								•	•	•	•	01
			3/4 in	11T 16/32DP								-	•	•	•	52
	101-2 (B)		7/8 in	13T 16/32DP								•	•	•	•	02
			1 in	15T 16/32DP								-	•	•	•	04
	127-2 (C)		1 1/4 in	14T 12/24DP								-	-	-	•	07

High-pressure relief valve **18 28 45 63**

18	High-pressure relief valve		Setting range Δp_{HD}		250 ... 320 bar		without bypass		•	•	•	•	3
	direct operated, fixed setting						with bypass		•	•	•	•	5
			100 ... 250 bar				without bypass		-	•	•	•	4
							with bypass		-	•	•	•	6

Filtration boost circuit/external boost pressure supply **18 28 45 63**

19	Filtration in the boost pump suction line											•	•	•	•	S
	Filtration in the boost pump pressure line											-	• ⁵⁾	• ⁵⁾	•	D
	Ports for external boost circuit filtration (F_e and G (F_a))															
	External boost pressure supply (on version without integrated boost pump - N, K)											•	•	•	•	E

Connector for solenoids⁶⁾ **18 28 45 63**

20	Without connector (without symbol), only with purely hydraulic controls											•	•	•	•	
	DEUTSCH molded connector		without suppressor diode									•	•	•	•	P
	2-pin, DT04-2P		with suppressor diode (only for EZ, DA and ED switching solenoid)									•	•	•	•	Q

Flushing valve **18 28 45 63**

21	Without flushing valve (without symbol)											•	•	•	•	
	Flushing valve		SAE connection diagram, metric mounting									•	•	•	•	1
			metric threaded ports									•	•	•	•	3

Standard/special version

22	Standard version											without code				
	Special version															-S

• = Available ◦ = On request - = Not available = Preferred program

Notice

- ▶ Note the project planning notes on page 59!
- ▶ In addition to the type code, please specify the relevant technical data when placing your order.
- ▶ Please note that not all type code combinations are available although the individual functions are marked as being available.

3) Specifications for version with integrated boost pump, please contact us for version without boost pump

4) Hub for splined shaft according to ANSI B92.1a-1976 (drive shaft allocation according to SAE J744)

5) Pressure filtration is not possible in connection with DA control valve

6) Connectors for other electric components may deviate

Hydraulic fluids

The axial piston unit is designed for operation with HLP mineral oil according to DIN 51524.

Application instructions and requirements for hydraulic fluid selection, behavior during operation as well as disposal and environmental protection should be taken from the following data sheets before the start of project planning:

- ▶ 90220: Hydraulic fluids based on mineral oils and related hydrocarbons
- ▶ 90221: Environmentally acceptable hydraulic fluids
- ▶ 90222: Fire-resistant, water-free hydraulic fluids (HFDR/HFDU)
- ▶ 90225: Limited technical data for operation with waterfree and water-containing fire-resistant hydraulic fluids (HFDR, HFDU, HFAE, HFAS, HFB, HFC)

Selection of hydraulic fluid

Bosch Rexroth evaluates hydraulic fluids on the basis of the Fluid Rating according to the technical data sheet 90235.

Hydraulic fluids with positive evaluation in the Fluid Rating are provided in the following technical data sheet:

- ▶ 90245: Bosch Rexroth Fluid Rating List for Rexroth hydraulic components (pumps and motors)

The hydraulic fluid should be selected so that the operating viscosity in the operating temperature range is within the optimum range (v_{opt} ; see selection diagram).

Viscosity and temperature of hydraulic fluids

	Viscosity	Shaft seal	Temperature ³⁾	Comment
Cold start	$v_{max} \leq 1600 \text{ mm}^2/\text{s}$	NBR ²⁾	$\theta_{St} \geq -40 \text{ }^\circ\text{C}$	$t \leq 3\text{min}$, without load ($p \leq 50 \text{ bar}$), $n \leq 1000 \text{ rpm}$ Permissible temperature difference between axial piston unit and hydraulic fluid in the system maximum 25 K
		FKM	$\theta_{St} \geq -25 \text{ }^\circ\text{C}$	
Warm-up phase	$v = 1600 \dots 400 \text{ mm}^2/\text{s}$			$t \leq 15\text{min}$, $p \leq 0.7 \times p_{nom}$ and $n \leq 0.5 \times n_{nom}$
Continuous operation	$v = 400 \dots 10 \text{ mm}^2/\text{s}^{1)}$	NBR ²⁾	$\theta \leq +85 \text{ }^\circ\text{C}$	measured at port T
		FKM	$\theta \leq +110 \text{ }^\circ\text{C}$	
	$v_{opt} = 36 \dots 16 \text{ mm}^2/\text{s}$			optimal operating viscosity and efficiency range
Short-term operation	$v_{min} = 10 \dots 7 \text{ mm}^2/\text{s}$	NBR ²⁾	$\theta \leq +85 \text{ }^\circ\text{C}$	$t \leq 3\text{min}$, $p \leq 0.3 \times p_{nom}$, measured at port T
		FKM	$\theta \leq +110 \text{ }^\circ\text{C}$	

▼ Selection diagram

Maximum permissible viscosity on cold start

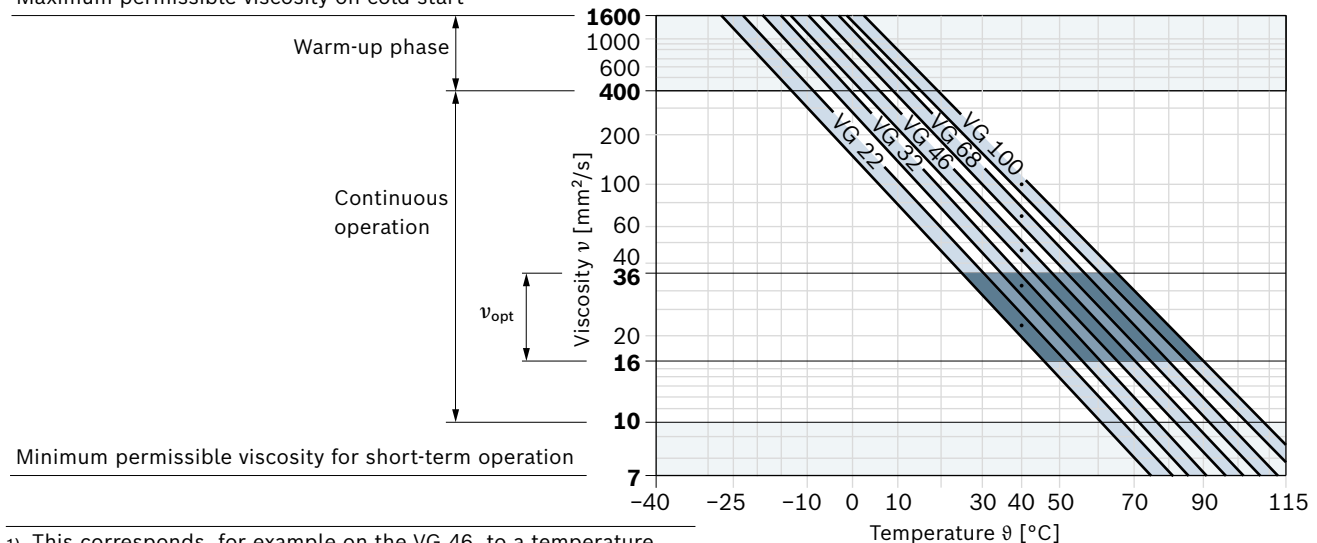

1) This corresponds, for example on the VG 46, to a temperature range of +4 °C to +85 °C (see selection diagram)

2) Special version, please contact us

3) If the temperature at extreme operating parameters cannot be adhered to, please contact us.

Filtration of the hydraulic fluid

Finer filtration improves the cleanliness level of the hydraulic fluid, which increases the service life of the axial piston unit.

A cleanliness level of at least 20/18/15 is to be maintained according to ISO 4406.

At a hydraulic fluid viscosity of less than 10 mm²/s (e.g. due to high temperatures during short-term operation) at the drain port, a cleanliness level of at least 19/17/14 according to ISO 4406 is required.

For example, the viscosity is 10 mm²/s at:

- ▶ HLP 32 a temperature of 73°C
- ▶ HLP 46 a temperature of 85°C

Working pressure range

Pressure at working port A or B		Definition
Nominal pressure p_{nom}	300 bar	The nominal pressure corresponds to the maximum design pressure.
Maximum pressure p_{max}	350 bar	The maximum pressure corresponds to the maximum working pressure within a single operating period. The sum of single operating periods must not exceed the total operating period.
Maximum single operating period	10 s	
Total operating period	300 h	
Minimum pressure (low-pressure side)	10 bar above case pressure	Minimum pressure on the low-pressure side (A or B) required to prevent damage to the axial piston unit.
Rate of pressure change $R_{A max}$	9000 bar/s	Maximum permissible pressure build-up and reduction speed during a pressure change across the entire pressure range.
Boost pump		Definition
Nominal pressure	NG18 20 bar	
$p_{Sp nom}$	NG28, 45, 63 25 bar	
Maximum pressure	NG18 25 bar	
$p_{Sp max}$	NG28, 45, 63 40 bar	
Pressure at suction port S (inlet)		
Continuous $p_{S min}$	≥0.8 bar abs.	$v \leq 30 \text{ mm}^2/\text{s}$
Short-term, at a cold start	≥0.5 bar abs.	$t < 3 \text{ min}$
Maximum pressure $p_{S max}$	≤5 bar abs.	
Control pressure		Definition
Minimum control pressure $p_{St min}$ at $n = 2000 \text{ rpm}$		Required control pressure p_{St} , to ensure the function of the control. The required control pressure is dependent on rotational speed, working pressure and the spring assembly of the stroking piston.
Controls EP, EZ, HW and HD	18 bar above case pressure	
Controls DA, DG, ET and ED	25 bar above case pressure	
Case pressure at port T		Definition
Maximum differential pressure $\Delta p_{T max}$	see the diagram	Permissible differential pressure at the shaft seal (case to ambient pressure)
Pressure peaks $p_{T peak}$	10 bar	$t < 0.1 \text{ s}$, maximum 1000 pressure peaks permissible

▼ **Maximum pressure p_{max} up to 350 bar and total operating period**

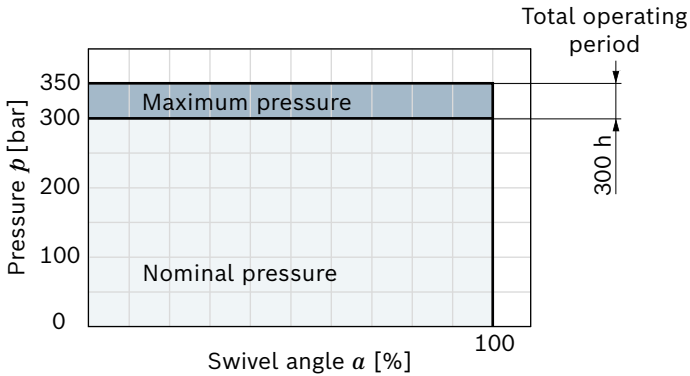

▼ **Rate of pressure change $R_{A\ max}$**

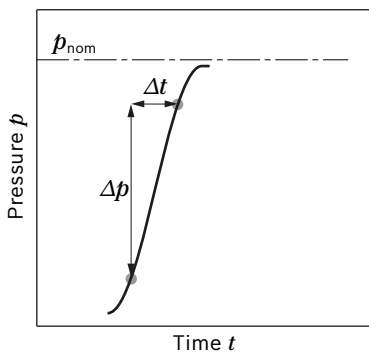

▼ **Maximum differential pressure at the shaft seal**

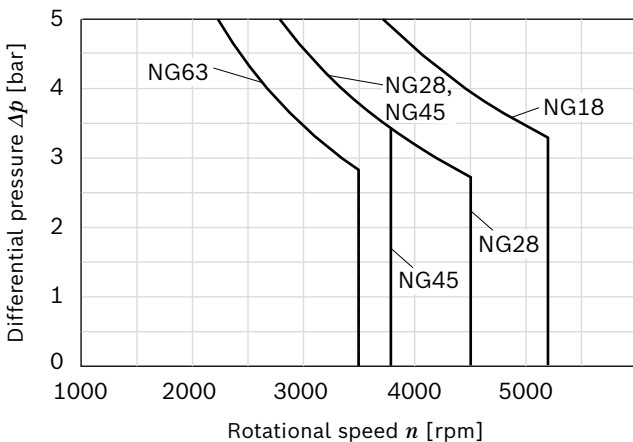

▼ **Pressure definition**

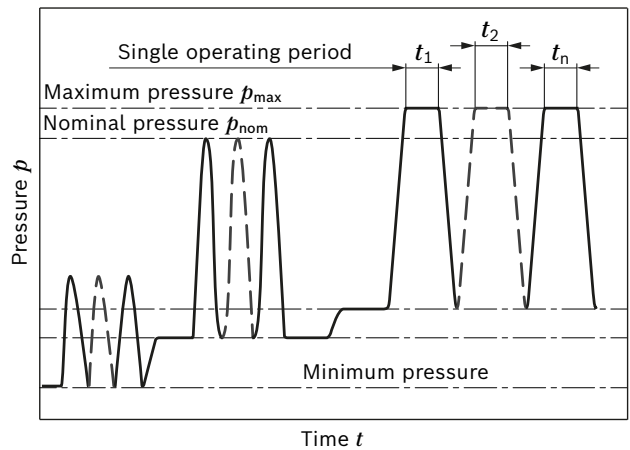

Total operating period = $t_1 + t_2 + \dots + t_n$

Notice

- ▶ Working pressure range applies when using hydraulic fluids based on mineral oils. Please contact us for values for other hydraulic fluids.
- ▶ In addition to the hydraulic fluid and the temperature, the service life of the shaft seal is influenced by the rotational speed of the axial piston unit and the case pressure.
- ▶ The service life of the shaft seal decreases with increasing frequency of pressure peaks and increasing mean differential pressure.
- ▶ The case pressure must be greater than the ambient pressure.

Technical data

Size		NG		18	28	45	63
Geometric displacement, per revolution	variable pump	$V_{g \max}$	cm ³	18	28	46	63
	boost pump (at $p = 20$ bar)	$V_{g Sp}$	cm ³	5.5	6.1	8.6	14.9
Rotational speed ¹⁾	maximum at $V_{g \max}$	n_{nom}	min ⁻¹	4000	3900	3300	3000
	limited maximum ²⁾	n_{max1}	min ⁻¹	4850	4200	3550	3250
	intermittent maximum ³⁾	n_{max2}	min ⁻¹	5200	4500	3800	3500
	minimum	n_{min}	min ⁻¹	500	500	500	500
Flow	at n_{nom} and $V_{g \max}$	q_v	l/min	72	109	152	189
Power ⁴⁾	at n_{nom} , $V_{g \max}$ and $\Delta p = 300$ bar	P	kW	36	54.6	75.9	94.5
Torque ⁴⁾	with $V_{g \max}$ and $\Delta p = 300$ bar	M	Nm	86	134	215	301
		M	Nm	28.6	44.6	72	100.3
Rotary stiffness of drive shaft	S	c	kNm/rad	20284	32143	53404	78370
	T	c	kNm/rad	–	–	73804	92368
Moment of inertia of the rotary group		J_{TW}	kgm ²	0.00093	0.0017	0.0033	0.0056
Maximum angular acceleration ⁵⁾		α	rad/s ²	6800	5500	4000	3300
Case volume		V	l	0.45	0.64	0.75	1.1
Weight (without through drive) approx. ⁶⁾		m	kg	18	25	27	39

Notice

- ▶ Theoretical values, without efficiency and tolerances; values rounded
- ▶ Operation above the maximum values or below the minimum values may result in a loss of function, a reduced service life or in the destruction of the axial piston unit. Bosch Rexroth recommends testing the loads by means of experiment or calculation / simulation and comparison with the permissible values.

Determining the operating characteristics

Flow	$q_v = \frac{V_g \times n \times \eta_v}{1000}$	[l/min]
Torque	$M = \frac{V_g \times \Delta p}{20 \times \pi \times \eta_{hm}}$	[Nm]
Power	$P = \frac{2 \pi \times M \times n}{60000} = \frac{q_v \times \Delta p}{600 \times \eta_t}$	[kW]

Key

V_g	Displacement per revolution [cm ³]
Δp	Differential pressure [bar]
n	Rotational speed [rpm]
η_v	Volumetric efficiency
η_{hm}	Hydraulic-mechanical efficiency
η_t	Total efficiency ($\eta_t = \eta_v \times \eta_{hm}$)

- The values are applicable:
 - for the optimum viscosity range from $\nu_{opt} = 36 \dots 16$ mm²/s
 - for hydraulic fluid based on mineral oils (for HF hydraulic fluids, observe the technical data in 90225)
- Valid at half corner power (e.g. at $V_{g \max}$ and $p_N/2$)
- Valid at $\Delta p = 70 \dots 150$ bar or $\Delta p < 300$ bar and $t < 0.1$ s
- Without boost pump

- The data are valid for values between the minimum required and maximum permissible rotational speed.
Valid for external excitation (e. g. diesel engine 2 to 8 times rotary frequency; cardan shaft twice the rotary frequency).
The limit value is only valid for a single pump.
The load capacity of the connection parts must be considered.
- Weight may vary by equipment.

Permissible radial and axial loading of the drive shaft

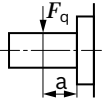
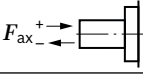
Size	NG		18	28	28	45	45	63	63	
Drive shaft		in	7/8	1	1 1/4	1	1 1/4	1 1/4	1 3/8	
Maximum radial force at distance a (to the shaft collar)		$F_{q \max}$	N	1300	2500	2500	3600	3600	5000	5000
		a	mm	16.5	17.5	17.5	17.5	17.5	17.5	17.5
Maximum axial force		$+ F_{ax \max}$	N	973	987	987	1500	1500	2200	2200
		$- F_{ax \max}$	N	973	987	987	1500	1500	2200	2200

Notice

- ▶ The axial and radial loading generally influence the bearing service life.
- ▶ Special requirements apply in the case of belt drive and cardan shaft. Please contact us.

Permissible input and through-drive torques

Size	NG		18	28	45	63	
Torque at $V_{g \max}$ and $\Delta p = 300 \text{ bar}^{1)}$	M	Nm	86	134	220	301	
Maximum input torque on drive shaft ²⁾ ANSI B92.1a (SAE J744)	S	$M_{E \max}$	Nm	192	314	314	602
			in	7/8	1	1	1 1/4
	T	$M_{E \max}$	Nm	–	602	602	970
			in	–	1 1/4	1 1/4	1 3/8
Maximum through-drive torque	$M_{D \max}$	Nm	112	220	314	439	

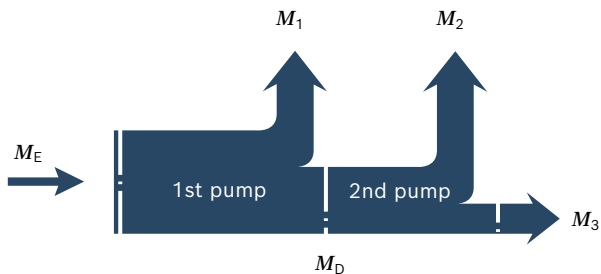
▼ Distribution of torques

Torque at 1st pump	M_1
Torque at 2nd pump	M_2
Torque at 3rd pump	M_3
Input torque	$M_E = M_1 + M_2 + M_3$
	$M_E < M_{E \max}$
Through-drive torque	$M_D = M_2 + M_3$
	$M_D < M_{D \max}$

1) Efficiency not considered

2) For drive shafts free of radial force

HD – Proportional control, hydraulic, pilot-pressure related

The output flow of the pump is infinitely variable between 0 and 100%, proportional to the difference in pilot pressure applied to the two pilot signal ports (**Y₁** and **Y₂**).

The pilot signal, coming from an external source, is a pressure signal. Flow is negligible, as the pilot signal acts only on the control spool of the control valve. This control spool then directs control oil into and out of the stroking cylinder to adjust pump displacement as required.

A feedback lever connected to the stroking piston maintains the pump flow for any given pilot signal within the control range.

If the pump is also equipped with a DA control valve (see page 14), automotive operation is possible for travel drives.

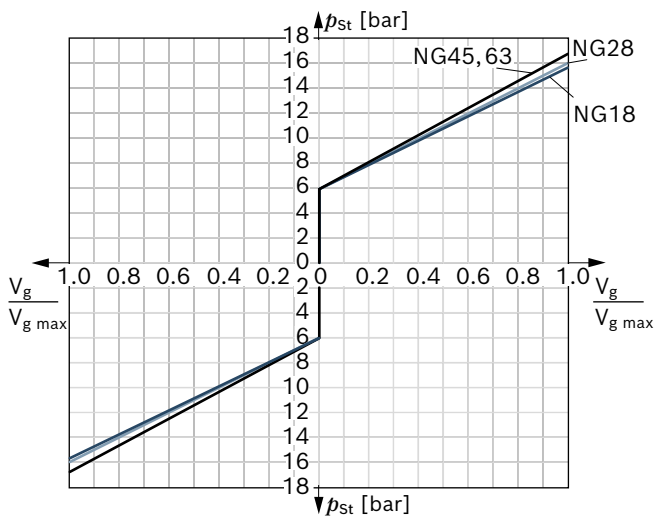

Size		18	28	45	63
Beginning of control (V_{g0})	p_{St} bar	6	6	6	6
End of control (V_{gmax})	p_{St} bar	15.7	16	16.7	16.7

Key

- V_g Displacement
- V_{g0} Displacement in neutral position
- V_{gmax} Maximum displacement
- p_{St} Pilot signal at port **Y₁**, **Y₂**

Notice

In the neutral position, the HD control module must be unloaded to reservoir via the external pilot control device.

▼ Circuit diagram, Version without pressure cut-off

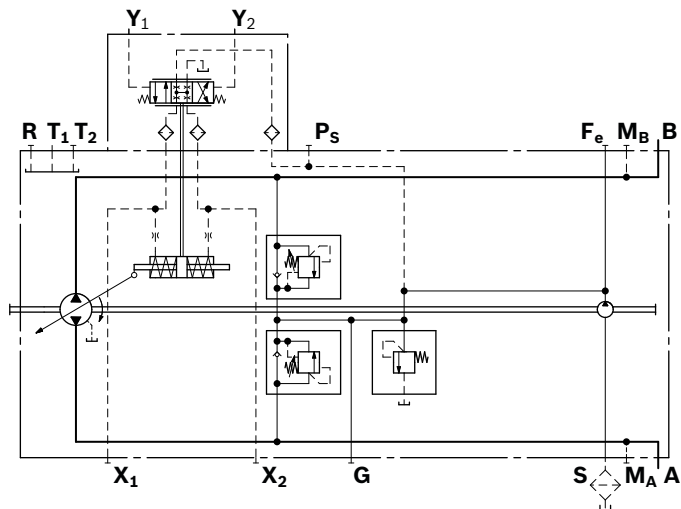

▼ Circuit diagram, Version with pressure cut-off

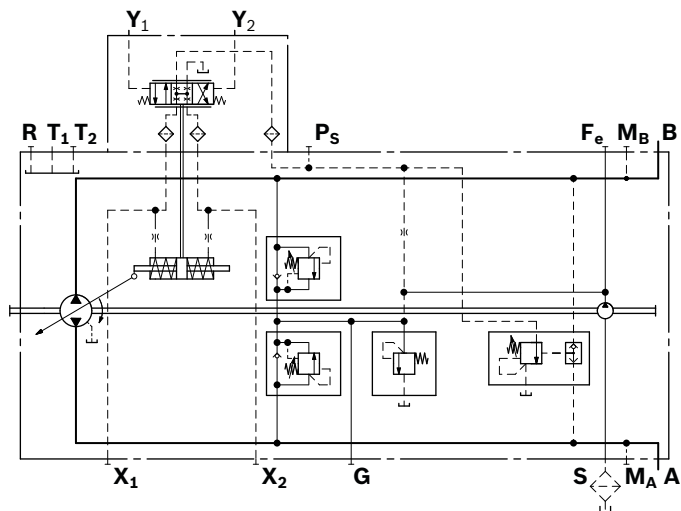

Correlation of direction of rotation, control and flow direction				
Direction of rotation	clockwise		counter-clockwise	
Pilot signal	Y₁	Y₂	Y₁	Y₂
Control pressure	X₁	X₂	X₁	X₂
Flow direction	A to B	B to A	B to A	A to B
Working pressure	M_B	M_A	M_A	M_B

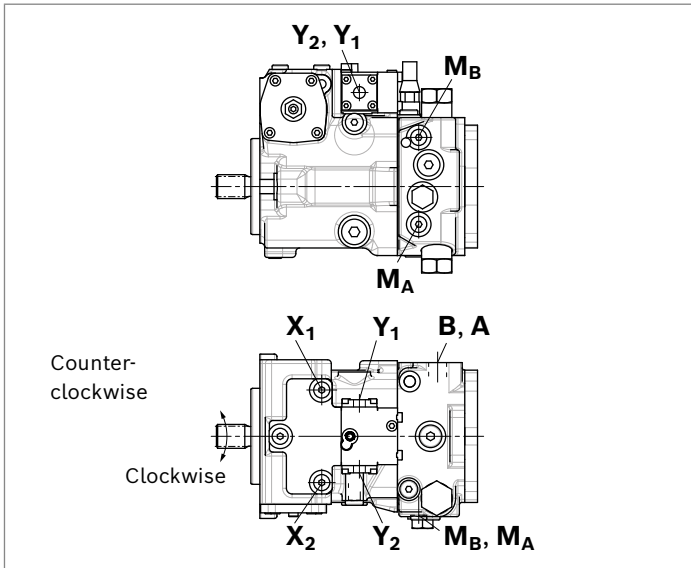

HW – Proportional control, hydraulic, mechanical servo

The output flow of the pump is infinitely variable between 0 and 100%, proportional to the swivel angle of the control lever.

A feedback lever connected to the stroking piston maintains the pump flow for any given position of the control lever. If the pump is also equipped with a DA control valve (see page 14), automotive operation is possible for travel drives.

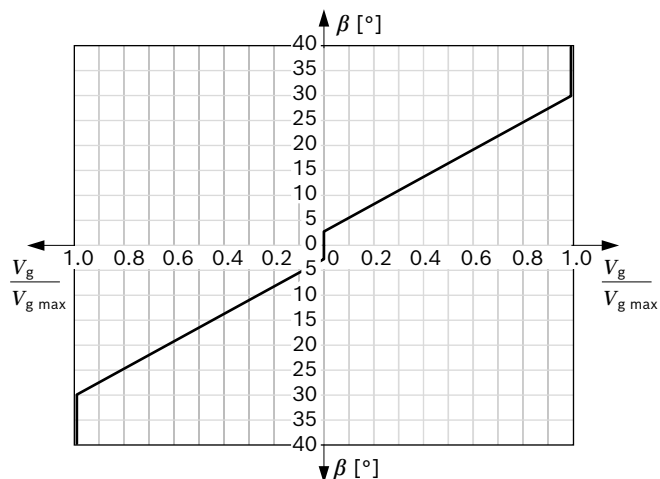

Size	18 ... 63
Beginning of control (V_{g0})	$\beta \pm 3^\circ$
End of control (V_{gmax})	$\beta \pm 30^\circ$
Rotational limiter control lever (internal)	$\beta \pm 38^\circ$

The maximum required torque at the control lever is 170 Ncm. To prevent damage to the HW control module, a positive mechanical stop of $33^\circ \pm 1$ must be provided for the HW control lever on the customer side.

Key

V_g	Displacement
V_{g0}	Displacement in neutral position
V_{gmax}	Maximum displacement
β	Swivel angle at the control lever

Notices

- ▶ Spring-centering enables the pump, depending on pressure and rotational speed, to move automatically to the neutral position ($V_g = 0$) as soon as there is no longer any torque on the control lever of the HW control module.
- ▶ As standard delivery, the control lever is oriented toward the through drive (see dimensions).
- ▶ If necessary, the position of the control lever can be changed. The procedure is defined in the instruction manual.
- ▶ The position of the control lever can deviate from the installation drawing.

Option: Neutral position switch

The switch contact in the neutral position switch is closed when the control lever on the HW control module is in its neutral position. The switch opens when the control lever is moved out of the central position in either direction. Thus, the neutral position switch provides a monitoring function for drive units that require the control lever at the HW control module to be in the neutral position during certain operating conditions (e.g. starting diesel engine).

Technical data

Load capacity	20 A (continuous), without switching operations
Switching capacity	15 A / 32 V (resistive load) 4 A / 32 V (inductive load)
Connector version	DEUTSCH DT04-2P-EP04 (mating connector, see page 53)

▼ Circuit diagram, Version without pressure cut-off

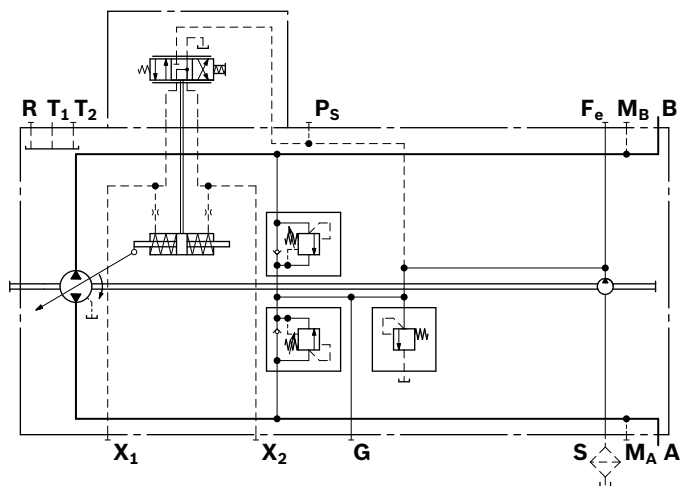

▼ **Circuit diagram, Version with neutral position switch and pressure cut-off**

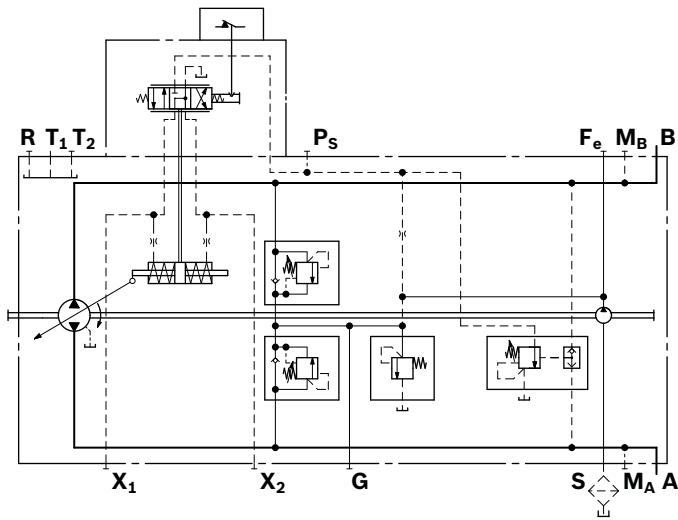

Correlation of direction of rotation, control and flow direction				
Direction of rotation	clockwise		counter-clockwise	
Lever direction	a	b	a	b
Control pressure	X ₂	X ₁	X ₂	X ₁
Flow direction	B to A	A to B	A to B	B to A
Working pressure	M _A	M _B	M _B	M _A

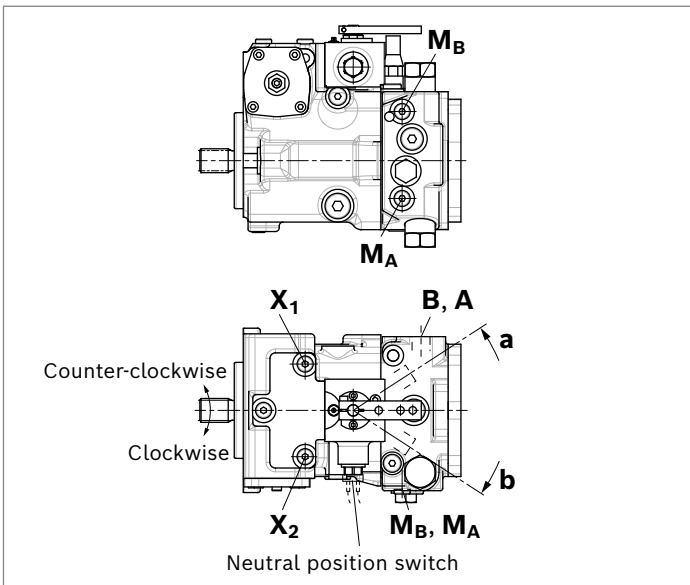

DA – Automatic control, speed related

The DA closed loop control is an engine speed-dependent system for travel drives. The built-in DA control valve generates a pilot pressure that is proportional to pump drive speed. This pilot pressure is directed to the stroking cylinder of the pump by an electromagnetically actuated 4/3-way directional valve. The pump displacement is infinitely variable in each flow direction and is influenced by both pump drive speed and system pressure. The flow direction (e.g. machine moving forward or backward) is determined by either solenoid **a** or **b** being activated. Increasing the pump drive speed generates a higher pilot pressure from the DA control valve, with a subsequent increase in pump flow.

Depending on the selected pump operating characteristics, increasing system pressure (e.g. machine load) causes the pump to swivel back towards a smaller displacement. An overload protection for the engine (against stalling) is achieved by combining this pressure-dependent reduction in pump stroke with a reduction in pilot pressure as the engine speed drops.

Any additional power requirement, e.g. for hydraulic functions from attachments, could cause the engine speed to drop further. This will cause a further reduction in pilot pressure and thus of the pump displacement. Automatic power distribution and full exploitation of the available power are achieved in this way, both for the travel drive and for the implement hydraulics, with priority given to the implement hydraulics.

Various override options are available for DA control function to allow controlled operation of the implement hydraulics with high rpm at reduced travel speed. The DA control valve can also be used in pumps with DG, HW, HD and EP control modules to protect the combustion engine against overload.

Notices

DA closed loop control is only suitable for certain types of travel drive systems and requires review of the motor and vehicle parameters to ensure that the pump is used correctly and that machine operation is safe and efficient. We recommend that all DA applications be reviewed by a Bosch Rexroth application engineer.

Technical data, switching solenoid	DA1	DA2
Voltage	12 V ($\pm 20\%$)	24 V ($\pm 20\%$)
Neutral position $V_g = 0$	de-energized	de-energized
Position $V_{g \max}$	current switched on	current switched on
Nominal resistance (at 20 °C)	5.5 Ω	21.7 Ω
Nominal power	26.2 W	26.5 W
Minimum active current required	1.32 A	0.67 A
Duty cycle	100%	100%
Type of protection: see connector version page 53		

Correlation of direction of rotation, control and flow direction				
Direction of rotation	clockwise		counter-clockwise	
Actuation	a	b	a	b
Switching solenoid				
Control pressure	X₂	X₁	X₂	X₁
Flow direction	B to A	A to B	A to B	B to A
Working pressure	M_A	M_B	M_B	M_A

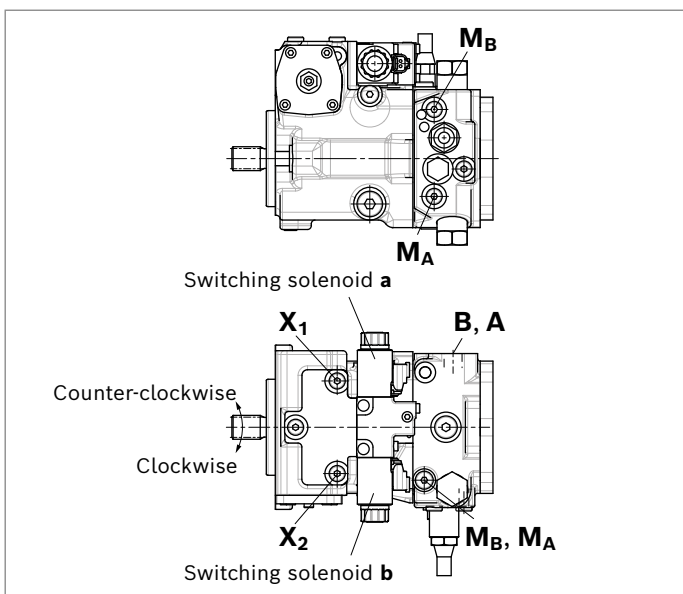

DA..2 – DA control valve, fixed setting

Pilot pressure is generated in relation to drive speed.

▼ **Circuit diagram, DA control valve, fixed setting, DA1D2/DA2D2¹⁾**

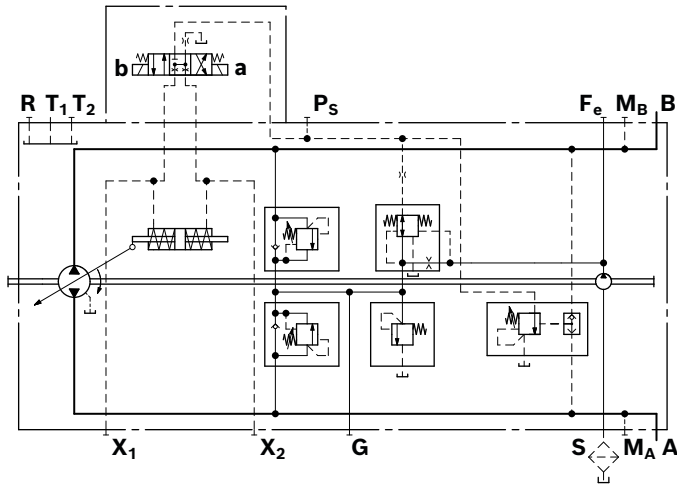

DA..3 – DA control valve, mechanically adjustable with position lever

Pilot pressure is generated in relation to drive speed.

Any reduction of pilot pressure possible, independently of drive speed, through mechanical actuation of the position lever (inch function).

The maximum permissible actuation torque at the position lever is $T_{max} = 4 \text{ Nm}$.

In the standard version, the position lever is configured for control module.

The maximum angle of rotation is 70°.

DA..3R

Direction of actuation of the position lever: clockwise

DA..3L

Direction of actuation of the position lever: counter-clockwise

▼ **Circuit diagram DA1D3/DA2D3¹⁾**

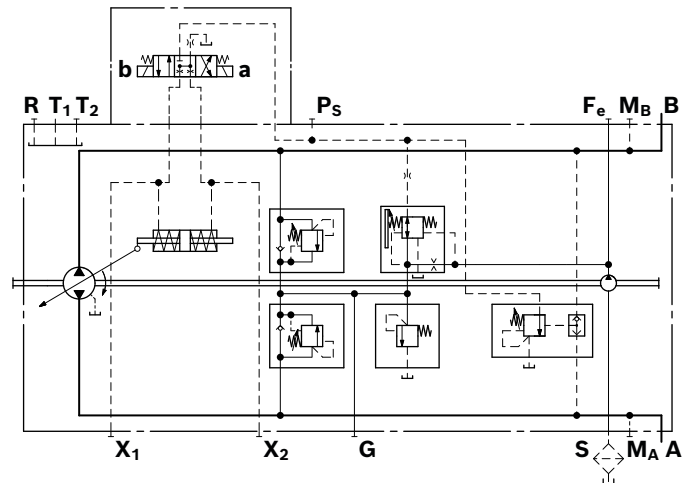

1) Size 63 with MH port

DA..7 – DA control valve, fixed setting, ports for pilot control device as inch valve

Any reduction of the pilot pressure possible, independent of the drive speed is achieved by the mechanical actuation of the pilot control device.

The pilot control device is installed separately from the pump (for example in the driver's cabin) and connected to the pump by two hydraulic control lines via ports **P_S** and **Y**. A suitable pilot control device must be ordered separately and is not included in the scope of delivery.

Notice: Rotary inch valves, see page 54.

▼ **Circuit diagram DA1D7/DA2D7¹⁾**

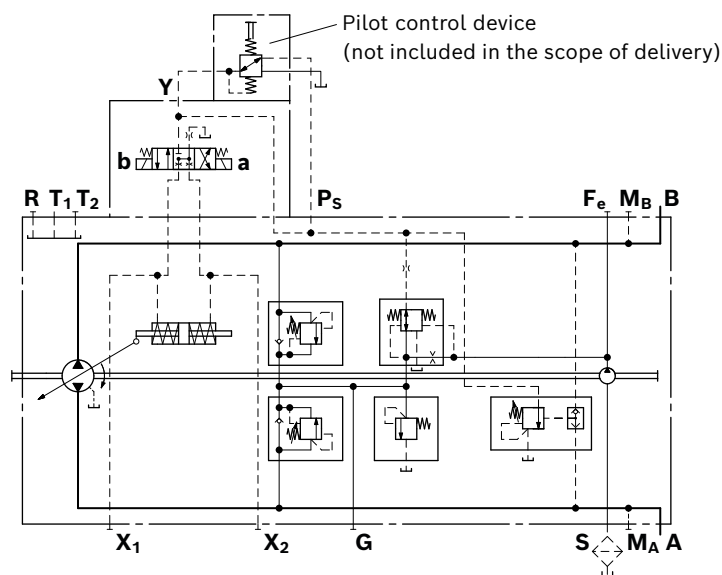

DA..8 – DA control valve, fixed setting and brake inch valve mounted

Only for pumps with DA control module

Permits reduction of the pilot pressure, independently of the drive speed, hydraulically controlled (port **Z**).

Control at port **Z** by means of brake fluid based on mineral oil.

Maximum permissible pilot pressure at port **Z**: 80 bar

▼ **Circuit diagram DA1D8/DA2D8¹⁾**

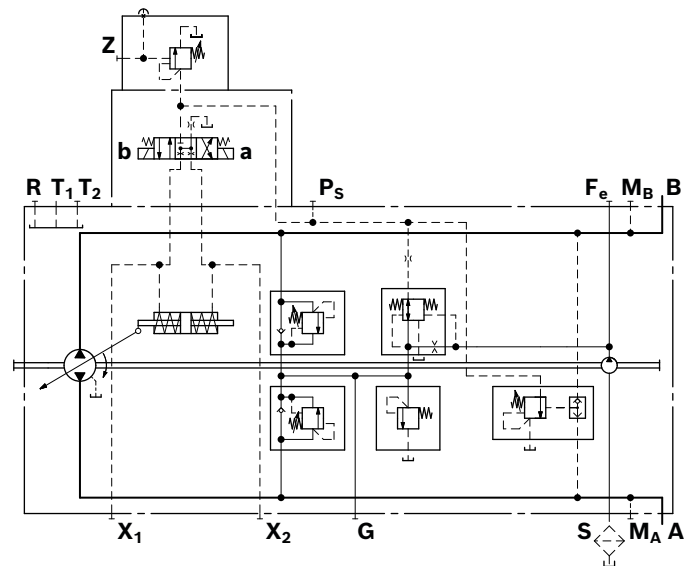

1) Size 63 with MH port

DG – Hydraulic control, direct operated

With the direct operated hydraulic control (DG), the output flow of the pump is controlled by a hydraulic control pressure, applied directly to the stroking piston through either port **X₁** or **X₂**.

Flow direction is determined by which control pressure port is pressurized.

Pump displacement is infinitely variable and proportional to the applied control pressure, but is also influenced by system pressure and pump drive speed.

In order to use the optional built-in pressure cut-off, port **P_S** must be used as source of the control pressure **X₁**, **X₂** generated on the customer side.

See page 46 for a functional description of the pressure cut-off.

Maximum permissible control pressure: 40 bar

Use of the DG control requires a review of the engine and vehicle parameters to ensure that the pump is set up correctly. We recommend that all DG applications be reviewed by a Bosch Rexroth application engineer.

If the pump is also equipped with a DA control valve (see page 14), automotive operation is possible for travel drives.

▼ Circuit diagram, Version without pressure cut-off

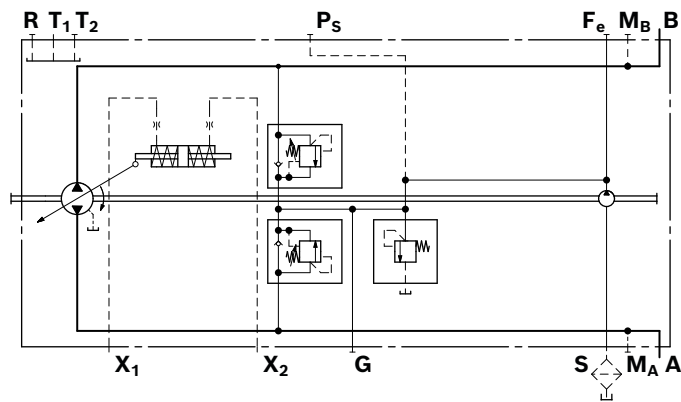

▼ Circuit diagram, Version with pressure cut-off

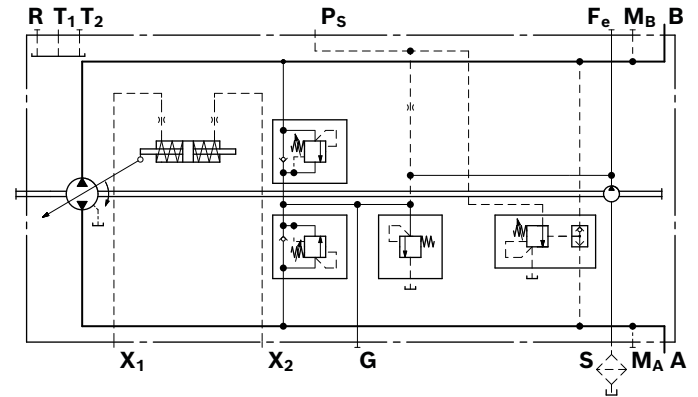

Correlation of direction of rotation, control and flow direction

Direction of rotation	clockwise		counter-clockwise	
Control pressure	X₁	X₂	X₁	X₂
Flow direction	A to B	B to A	B to A	A to B
Working pressure	M_B	M_A	M_A	M_B

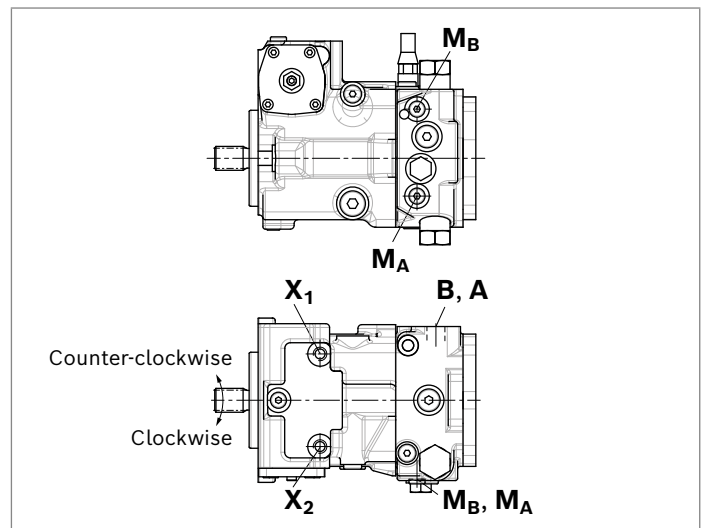

EP – Proportional control, electric

The output flow of the pump is infinitely variable between 0 and 100%, proportional to the electrical current supplied to solenoid **a** or **b**.

The electrical energy is converted into a force acting on the control spool.

This control spool then directs control oil into and out of the stroking cylinder to adjust pump displacement as required.

A feedback lever connected to the stroking piston maintains the pump flow for any given current within the control range.

If the pump is also equipped with a DA control valve (see page 14), automotive operation is possible for travel drives.

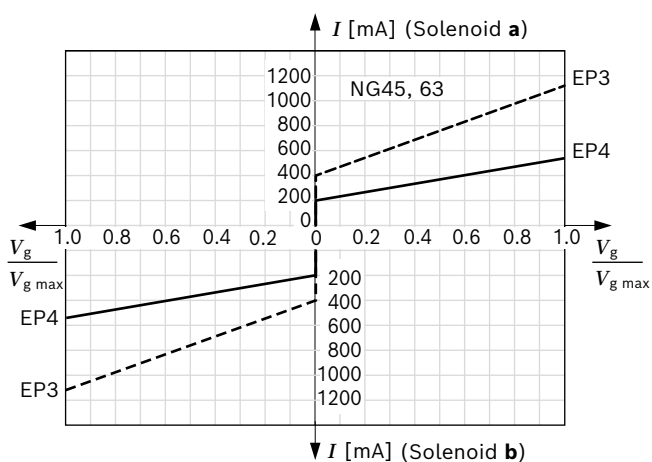

Notice

The proportional solenoids do not have manual override. Proportional solenoids with manual override and spring return are available on request.

Control current

	EP3	EP4	NG 18	NG 28	NG 45	NG 63
Start of control	mA	400	400	400	400	400
End of control	mA	1130	1140	1115	1115	1115
Start of control	mA	200	200	200	200	200
End of control	mA	565	570	560	560	560

1) Minimum required oscillation range of the control current ΔI_{p-p} (peak to peak) within the respective control range (start of control to end of control)

Technical data, proportional solenoid	EP3	EP4
Voltage	12 V ($\pm 20\%$)	24 V ($\pm 20\%$)
Control current		
Start of control at $V_g = 0$	400 mA	200 mA
End of control at $V_{g\ max}$	1200 mA	600 mA
Current limit	1.54 A	0.77 A
Nominal resistance (at 20 °C)	5.5 Ω	22.7 Ω
Dither		
Frequency	100 Hz	100 Hz
Minimum oscillation range ¹⁾	240 mA	120 mA
Duty cycle	100%	100%
Type of protection: see connector version page 53		

Various BODAS controllers with application software and amplifiers are available for controlling the proportional solenoids.

Further information can also be found on the Internet at www.boschrexroth.com/mobile-electronics

▼ Circuit diagram, Version without pressure cut-off

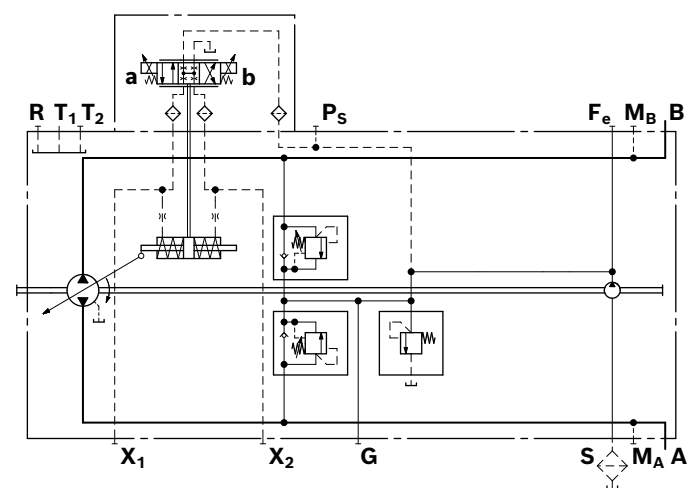

▼ Circuit diagram, Version with pressure cut-off

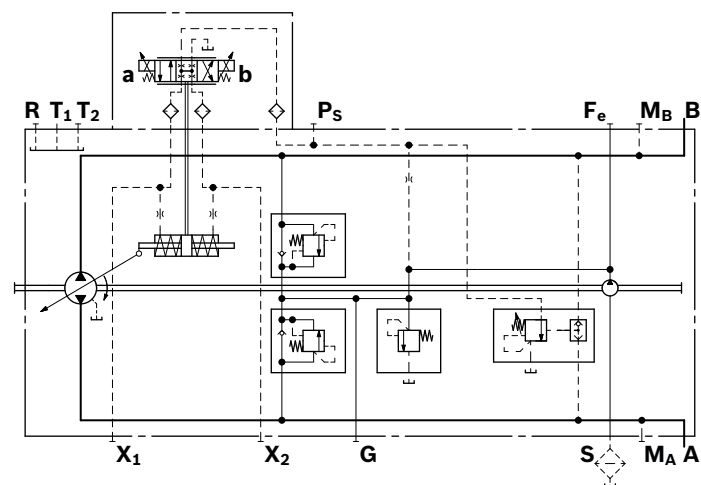

Correlation of direction of rotation, control and flow direction			
Direction of rotation	clockwise		counter-clockwise
Actuation	a	b	a b
Proportional solenoid			
Control pressure	X₁	X₂	X₁ X₂
Flow direction	A to B	B to A	B to A A to B
Working pressure	M_B	M_A	M_A M_B

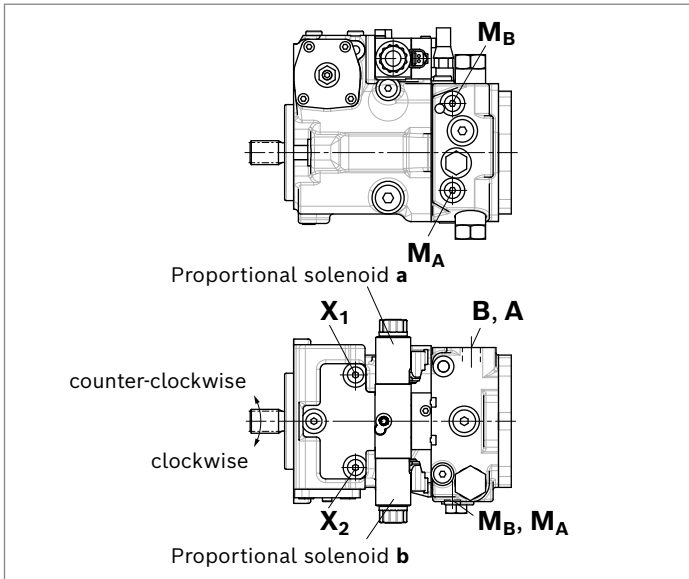

EZ – Two-point control, electric

By actuating either switching solenoid **a** or **b**, internal control pressure is applied directly to the stroking piston and the pump swivels to maximum displacement. The EZ control enables pump flow to be switched between $V_g = 0$ and $V_{g \max}$. Flow direction is determined by which solenoid is energized.

Technical data, switching solenoid	EZ1	EZ2
Voltage	12 V ($\pm 20\%$)	24 V ($\pm 20\%$)
Neutral position $V_g = 0$	de-energized	de-energized
Position $V_g \max$	Current switched on	Current switched on
Nominal resistance (at 20 °C)	5.5 Ω	21.7 Ω
Nominal power	26.2 W	26.5 W
Minimum active current required	1.32 A	0.67 A
Duty cycle	100%	100%
Type of protection: see connector version page 53		

▼ Circuit diagram, Version without pressure cut-off

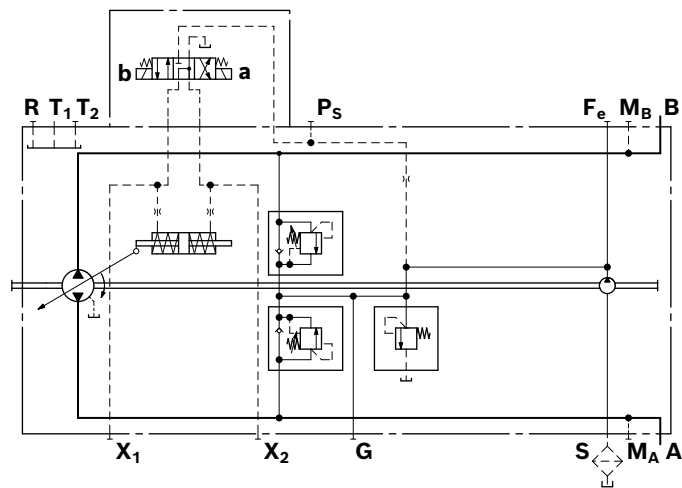

▼ Circuit diagram, Version with pressure cut-off

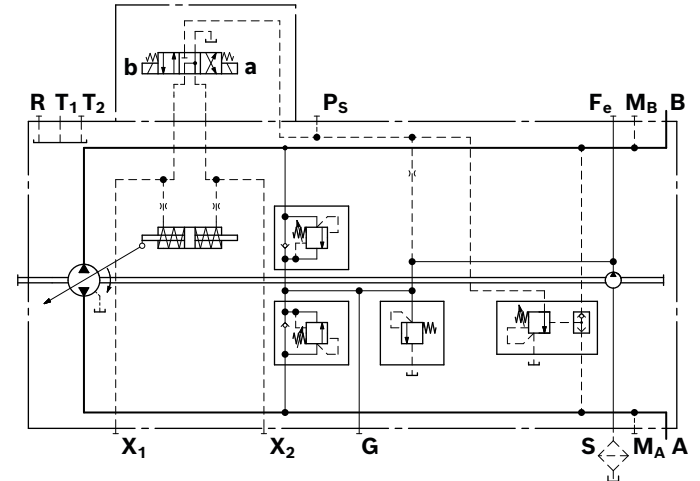

Correlation of direction of rotation, control and flow direction

Direction of rotation	clockwise		counter-clockwise	
Actuation	a	b	a	b
Switching solenoid				
Control pressure	X2	X1	X2	X1
Flow direction	B to A	A to B	A to B	B to A
Working pressure	MA	MB	MB	MA

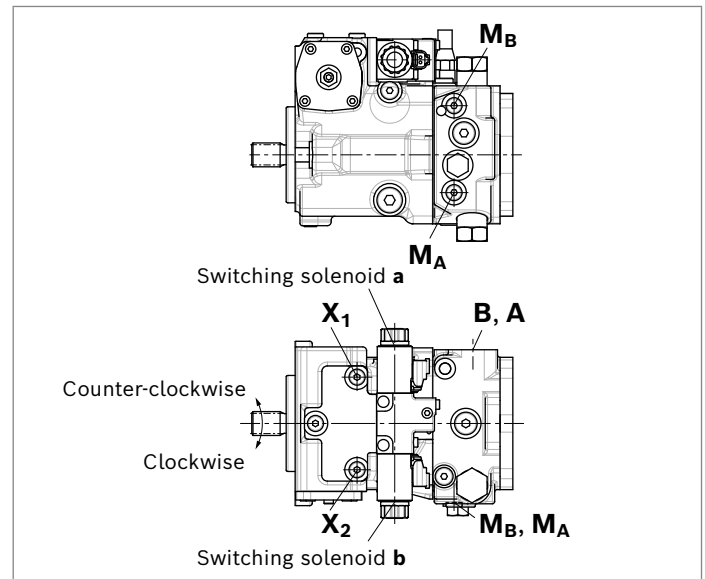

ET – Electric control, direct operated

The output flow of the pump is infinitely variable in the range between 0 and 100%. Depending on the preselected current I at solenoids **a** and **b** of the pressure reducing valves, the stroking cylinder of the pump is proportionally supplied with control pressure. The two control pressures X_1 and X_2 can be controlled independently. The pump displacement that arises at a certain control current is dependent on the rotational speed and working pressure of the pump. A different flow direction is associated with each pressure reducing valve.

Maximum permissible control pressure P_S : 40 bar.

Technical data, pressure reducing valve ¹⁾	ET3	ET4
On-board voltage in the vehicle	12 V	24 V
Permissible voltage U	9.6 ... 28.8 V	
Current limit	1.8 A	
Nominal resistance (at 20 °C)	2.4 Ω	
Dither		
Frequency	100 Hz	
Minimum oscillation range ²⁾	360 mA	
Duty cycle	100%	
Type of protection: see connector version page 53		

▼ Circuit diagram, Standard version

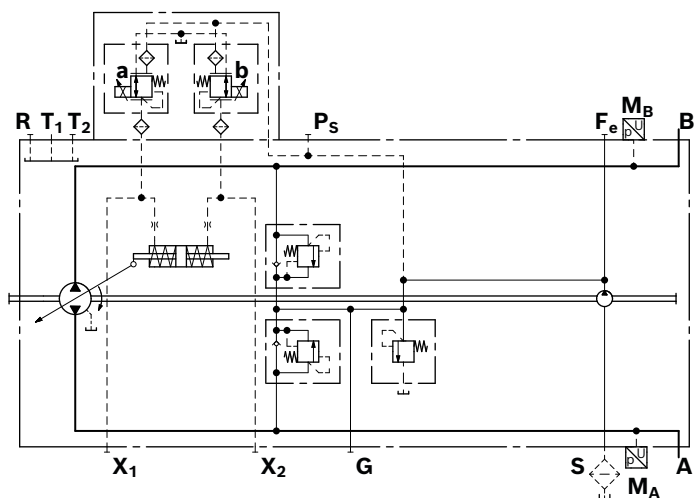

ET is preferably used with BODAS eDA (data sheet 95315). To this end, pressure sensors are required.

One prerequisite for the combination with pressure sensors is a port plate version with M_A/M_B according to ISO 6149 M14 \times 1.5. This design is only available for selected port plates, please contact us.

▼ Circuit diagram, Version without pressure sensors

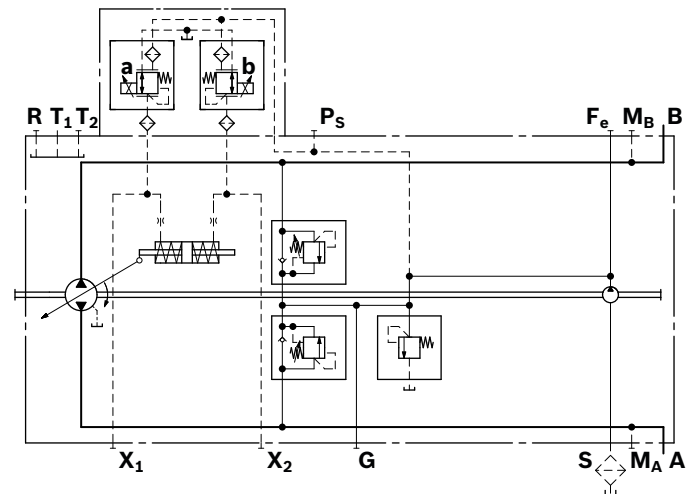

Correlation of direction of rotation, control and flow direction

Direction of rotation	clockwise		counter-clockwise	
	a	b	a	b
Actuation Pressure reducing valve				
Control pressure	X_1	X_2	X_1	X_2
Flow direction	A to B	B to A	B to A	A to B
Working pressure	M_B	M_A	M_A	M_B

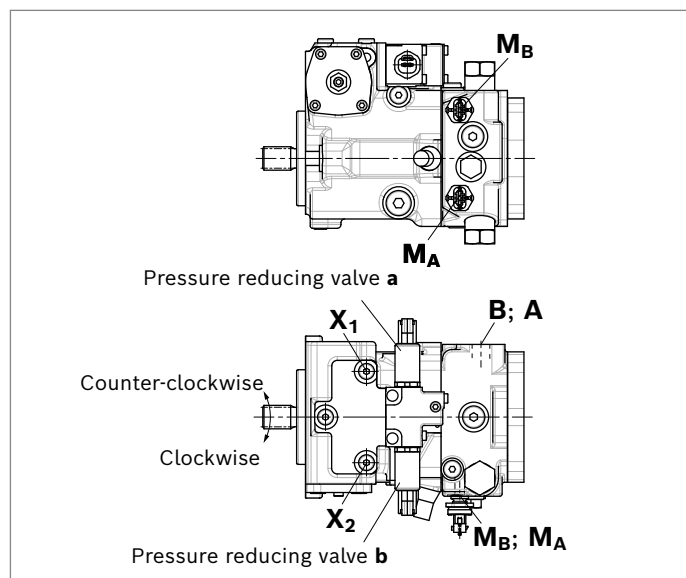

1) For further information on the pressure reducing valve, see data sheet 58032.

Notice: The leakage flow and the control flow differ from the parameter in data sheet 58032.

2) Minimum required oscillation range of the control current ΔI_{p-p} (peak to peak) within the respective control range (start of control to end of control)

ED – Electric pressure control

The working pressure of the electric pressure control ED can be set continuously via a pressure reducing valve. The pressure value depends on the control current pressurizing the solenoid at the pressure reducing valve. The ED pressure control holds the set working pressure on a constant level. Each load pressure change at the consumer changes the stroking piston and thus the flow until the pressure deviation is corrected according to the specified current.

The higher the control current, the lower the set pressure value. For maximum control current, high and low-pressure sides are balanced and the pump swivels into its central position (neutral position). If the pressure reducing valve is not pressurized with control current, the pressure is limited by the mechanical pressure setting at the pressure cut-off. By actuating the electric 4/2 directional valve, supply of the stroking chambers is exchanged, and the flow direction of the pump is inverted.

The maximum permissible pressure setting of the pressure cut-off combined with the ED pressure control is 350 bar.

Technical data, pressure reducing valve	ED2, ED4
Voltage	24 V ($\pm 20\%$)
Current limit	0.77 A
Nominal resistance (at 20 °C)	22.7 Ω
Dither	
Frequency	100 Hz
Minimum oscillation range ¹⁾	120 mA
Duty cycle	100%
Type of protection according to DIN VDE 0470/EN 60529	IP67 and IP69K
Applies to connector DEUTSCH DT04-2P, see page 53	

Technical data, switching solenoid	ED2, ED4
Voltage	24 V ($\pm 20\%$)
Nominal resistance (at 20 °C)	21.7 Ω
Nominal power	26.5 W
Minimum active current required	0.67A
Duty cycle	100%
Type of protection according to DIN VDE 0470/EN 60529	IP67 and IP69K
Applies to connector DEUTSCH DT04-2P with suppressor diode, see page 53	

The values given are dependent on pressure, rotational speed, spring assembly, tolerances and therefore may differ.

▼ Circuit diagram, Standard version ED2

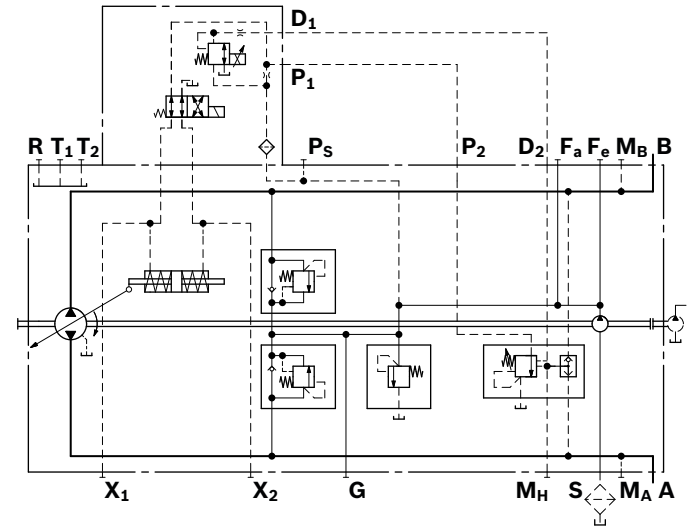

▼ Circuit diagram, Standard version ED4

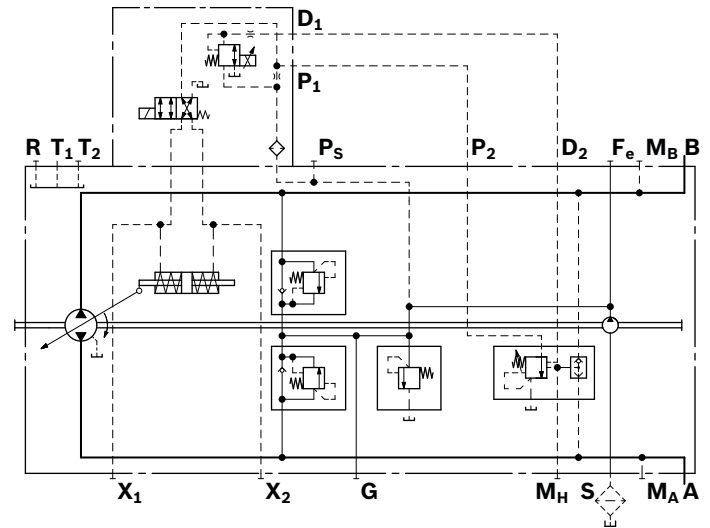

Correlation of direction of rotation, control and flow direction ¹⁾				
Version	ED2	ED2	ED4	ED4
Direction of rotation	clockwise	counter-clockwise	clockwise	counter-clockwise
Stroking chamber	X ₁	X ₁	X ₂	X ₂
Flow direction	A to B	B to A	B to A	A to B
Working pressure	M _B	M _A	M _A	M _B

▼ **Version ED2**

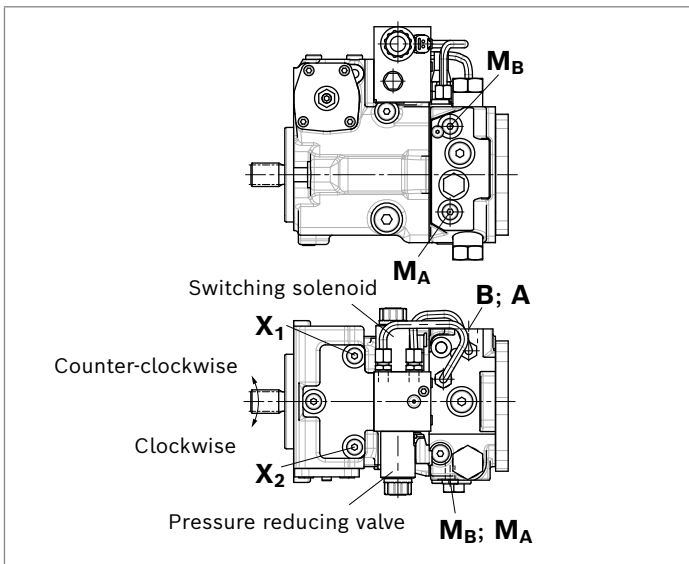

▼ **Version ED4**

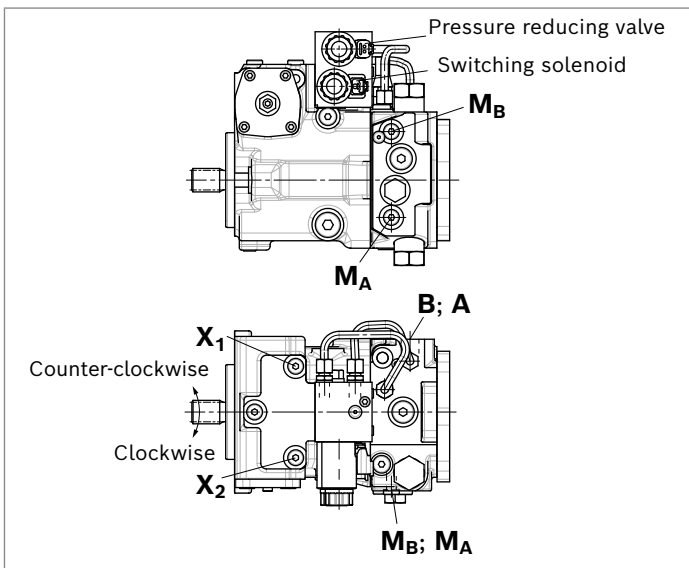

¹⁾ Parameters apply to switching solenoid and pressure reducing valve in de-energized condition

Dimensions, size 18

EP – Proportional control, electric

Standard: Threaded port **A** and **B**, same side right, suction port **S** bottom (16)

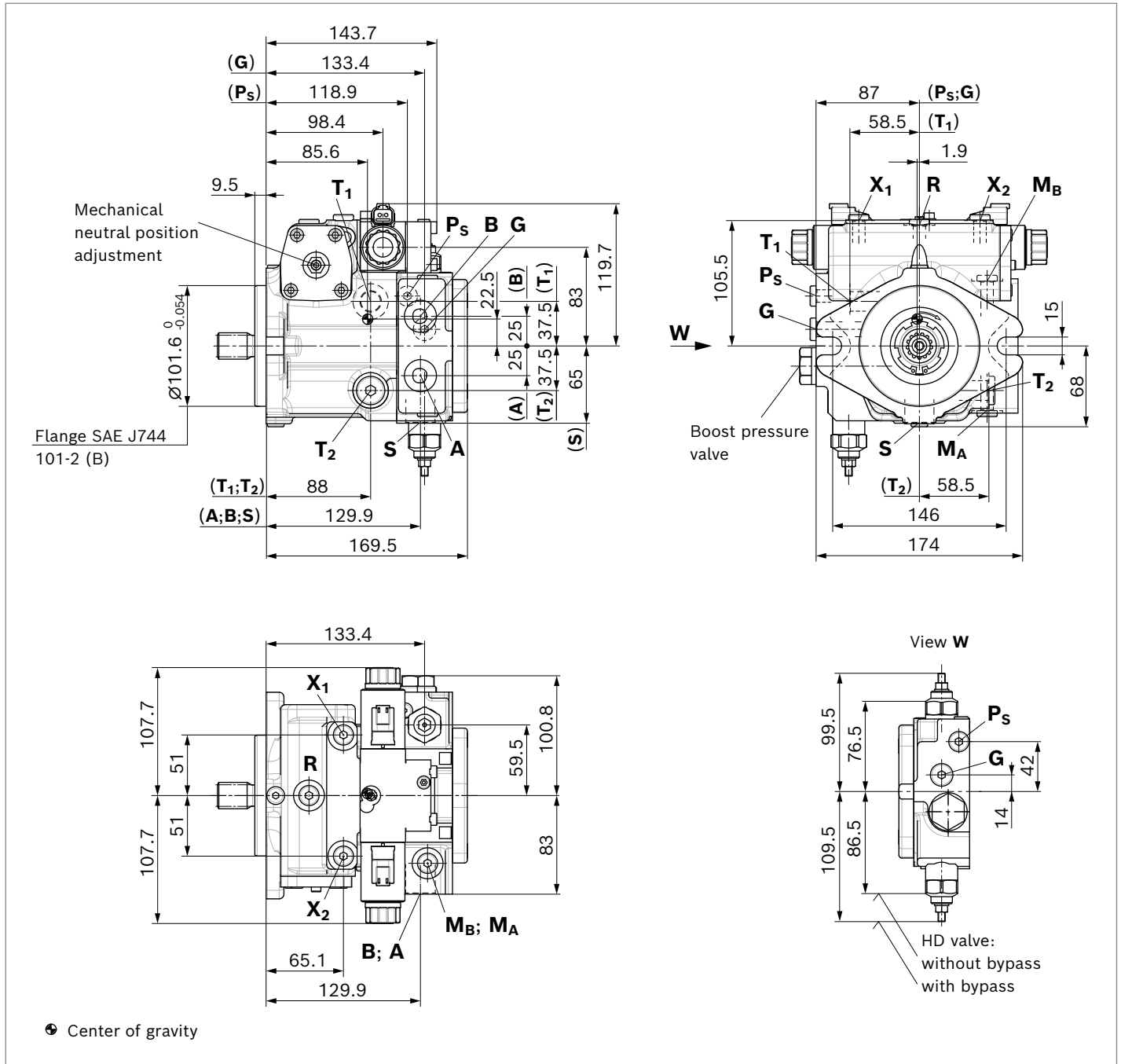

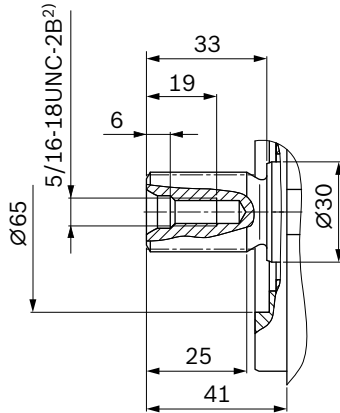
▼ **Splined shaft ANSI B92.1a****S – 7/8 in 13T 16/32DP¹⁾**

Ports		Standard	Size	p_{\max} [bar] ³⁾	State ⁷⁾
A, B	Working port	DIN 3852 ⁶⁾	M27 × 2; 16 deep	350	O
S	Suction port	DIN 3852 ⁶⁾	M26 × 1.5; 16 deep	5	O ⁴⁾
T₁	Drain port	DIN 3852 ⁶⁾	M18 × 1.5; 12 deep	3	O ⁵⁾
T₂	Drain port	DIN 3852 ⁶⁾	M18 × 1.5; 12 deep	3	X ⁵⁾
R	Air bleed port	DIN 3852 ⁶⁾	M12 × 1.5; 12 deep	3	X
X₁, X₂	Control pressure port (upstream of orifice)	DIN 3852 ⁶⁾	M12 × 1.5; 12 deep	25	X
G	Boost pressure port inlet	DIN 3852 ⁶⁾	M14 × 1.5; 12 deep	25	X
P_S	Pilot pressure port	DIN 3852 ⁶⁾	M12 × 1.5; 12 deep	25	X
M_A, M_B	Measuring port pressure A, B	DIN 3852 ⁶⁾	M12 × 1.5; 12 deep	350	X
Y₁, Y₂	Pilot pressure port (pilot signal HD only)	DIN 3852 ⁶⁾	M14 × 1.5; 12 deep	40	O

1) Involute spline according to ANSI B92.1a, 30° pressure angle, flat root, side fit, tolerance class 5

2) Thread according to ASME B1.1

3) Depending on the application, momentary pressure peaks can occur. Keep this in mind when selecting measuring devices and fittings.

4) Plugged for external boost pressure supply.

5) Depending on installation position, **T₁** or **T₂** must be connected (see also installation instructions on page 56).

6) The countersink can be deeper than specified in the standard. Ports designed for straight stud ends according to EN ISO 9974-2 type E

7) O = Must be connected (comes plugged)
X = Plugged (observe installation instructions)

▼ **HD** – Proportional control, hydraulic, pilot-pressure related

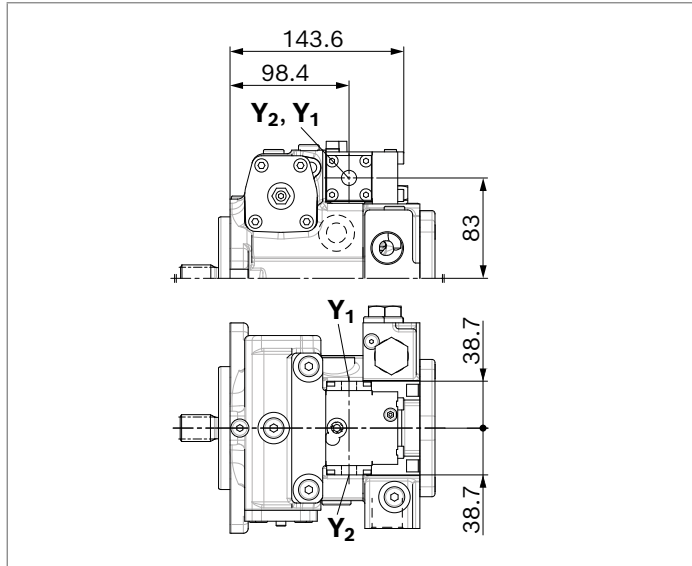

▼ **HW** – Proportional control, hydraulic, mechanical servo

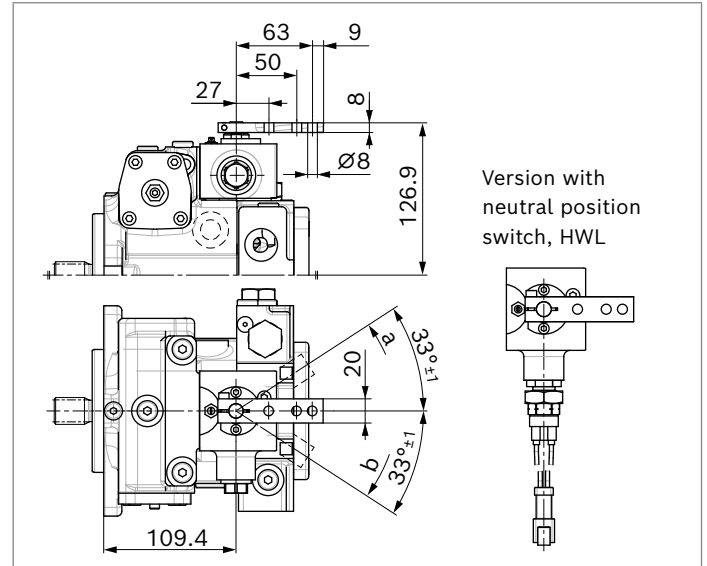

▼ **DG** – Hydraulic control, direct operated

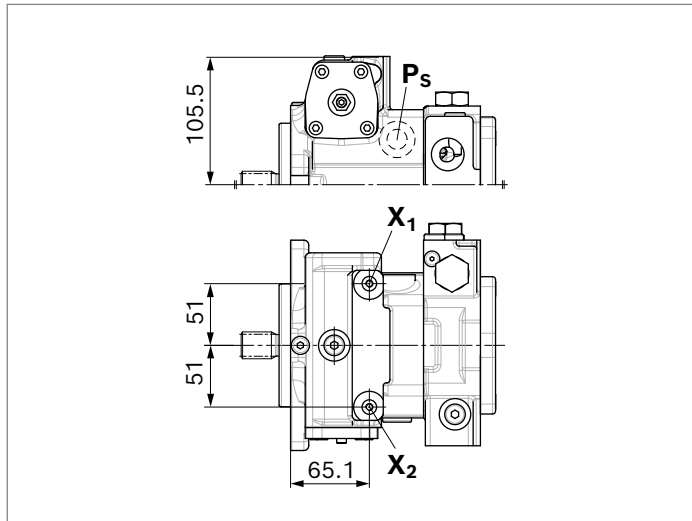

▼ **EZ** – Two-point control, electric

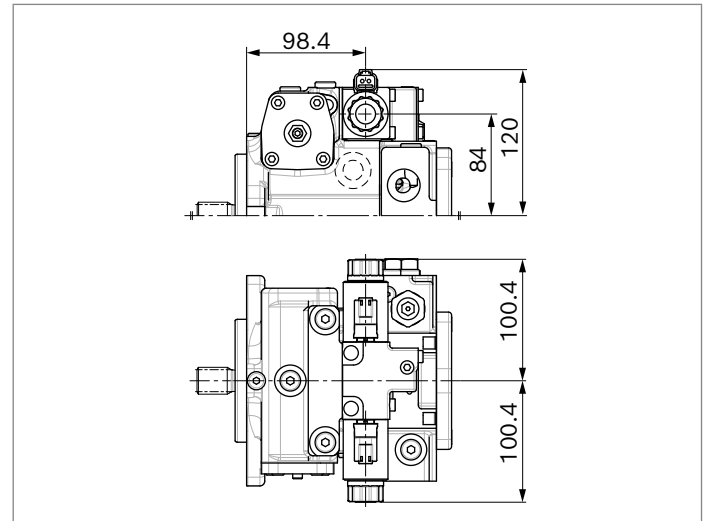

Dimensions, size 28

EP - Proportional control, electric

Standard: SAE working port **A** and **B**, same side left, suction port **S** bottom (10)

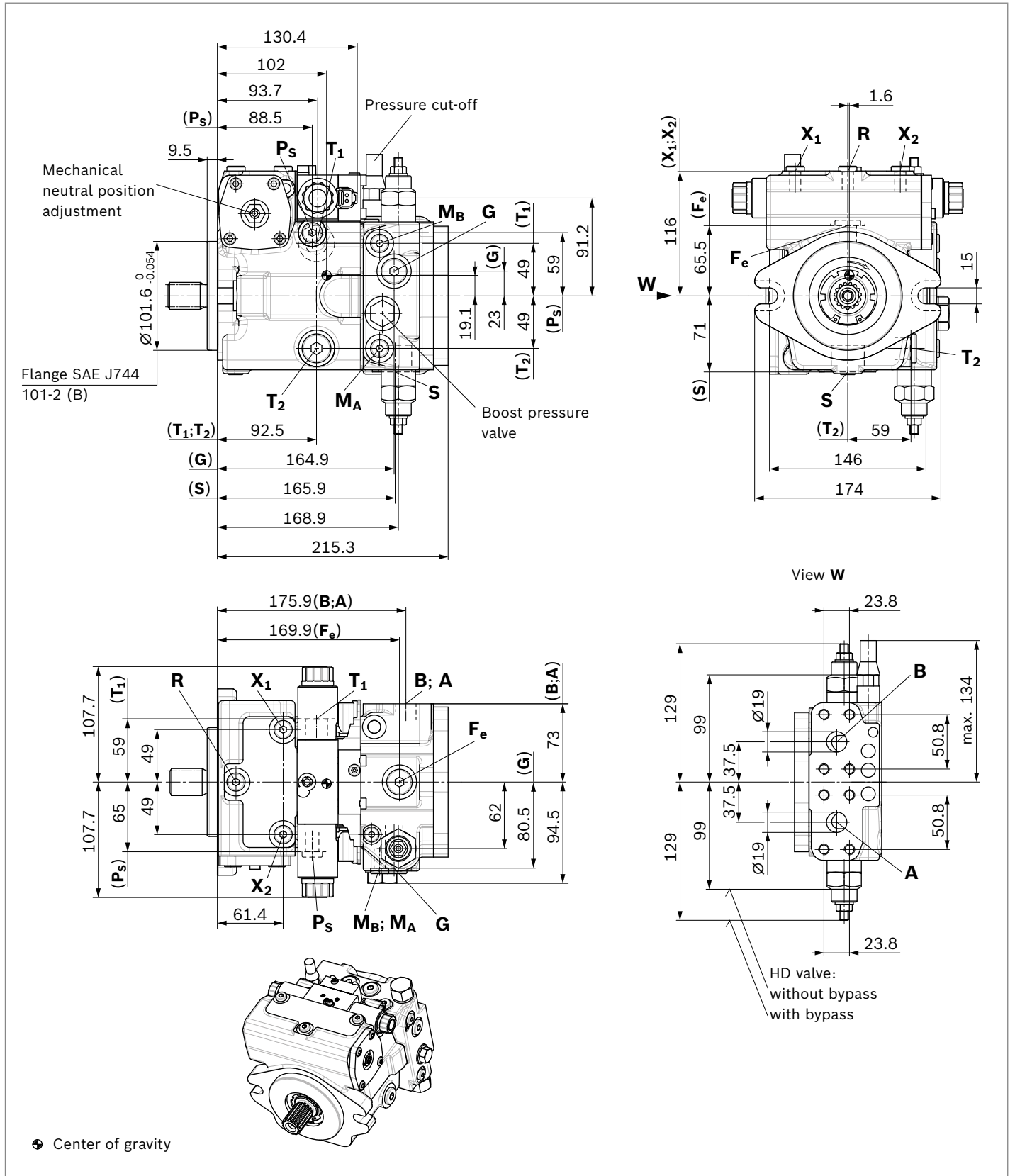

▼ **Splined shaft ANSI B92.1a**

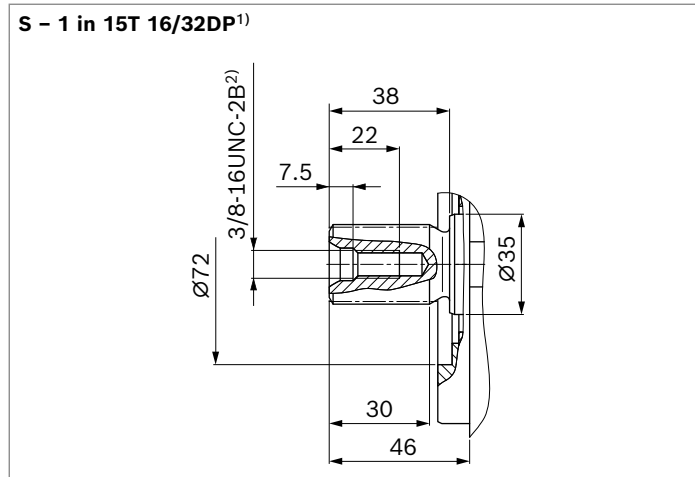

▼ **Splined shaft ANSI B92.1a**

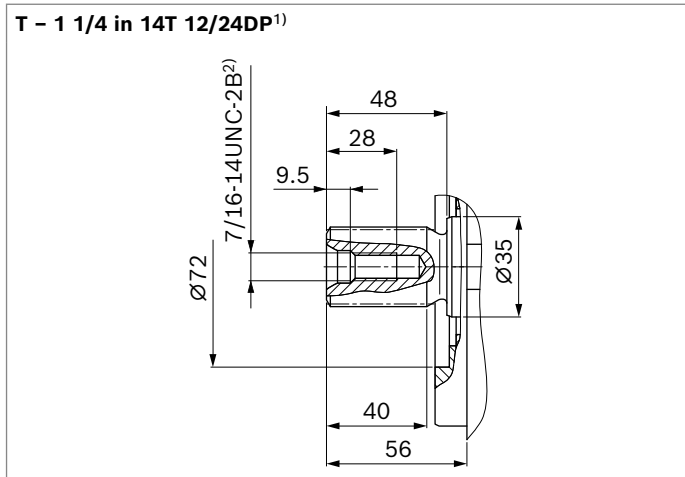

Ports		Standard	Size	p_{max} [bar] ³⁾	State ⁹⁾
A, B	Working port Fastening thread	SAEJ518 ⁴⁾ DIN 13	3/4 in M10 × 1.5; 17 deep	350	O
S	Suction port	DIN 3852 ⁷⁾	M33 × 2; 18 deep	5	O ⁵⁾
T₁	Drain port	DIN 3852 ⁷⁾	M22 × 1.5; 15 deep	3	O ⁶⁾
T₂	Drain port	DIN 3852 ⁷⁾	M22 × 1.5; 15 deep	3	X ⁶⁾
R	Air bleed port	DIN 3852 ⁷⁾	M12 × 1.5; 12 deep	3	X
X₁, X₂	Control pressure port (upstream of orifice)	DIN 3852 ⁷⁾	M12 × 1.5; 12 deep	40	X
X₃, X₄⁸⁾	Stroking chamber pressure port	DIN 3852 ⁷⁾	M10 × 1; 8 deep	40	X
G (F_a)	Boost pressure port inlet	DIN 3852 ⁷⁾	M18 × 1.5; 12 deep	40	X
G	Boost pressure port inlet (only DA control valve)	DIN 3852 ⁷⁾	M10 × 1; 8 deep	40	X
P_s	Pilot pressure port	DIN 3852 ⁷⁾	M14 × 1.5; 12 deep	40	X
Y	Pilot pressure port outlet (only DA..7)	DIN 3852 ⁷⁾	M14 × 1.5; 12 deep	40	O
M_A, M_B	Measuring port pressure A, B	DIN 3852 ⁷⁾	M12 × 1.5; 12 deep	350	X
F_e	Boost pressure port outlet	DIN 3852 ⁷⁾	M18 × 1.5; 12 deep	40	X
Y₁, Y₂	Pilot pressure port (pilot signal HD only)	DIN 3852 ⁷⁾	M14 × 1.5; 12 deep	40	O
Z	Pilot pressure port (inch signal only DA..8)	DIN 3852 ⁷⁾	M10 × 1; 8 deep	80	X

1) Involute spline according to ANSI B92.1a, 30° pressure angle, flat root, side fit, tolerance class 5
 2) Thread according to ASME B1.1
 3) Depending on the application, momentary pressure peaks can occur. Keep this in mind when selecting measuring devices and fittings.
 4) Only dimensions according to SAE J518, metric fastening thread is a deviation from the standard.
 5) Plugged for external boost pressure supply.

6) Depending on installation position, **T₁** or **T₂** must be connected (see also installation instructions on page 56).
 7) The countersink can be deeper than specified in the standard. Ports designed for straight stud ends according to EN ISO 9974-2 type E
 8) Optional, see page 49
 9) O = Must be connected (comes plugged)
 X = Plugged (in normal operation)

▼ **HD** – Proportional control, hydraulic, pilot-pressure related

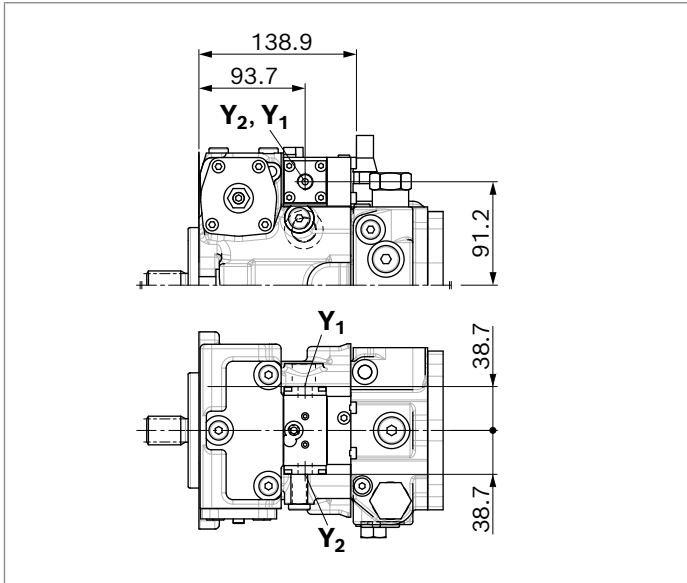

▼ **HW** – Proportional control, hydraulic, mechanical servo

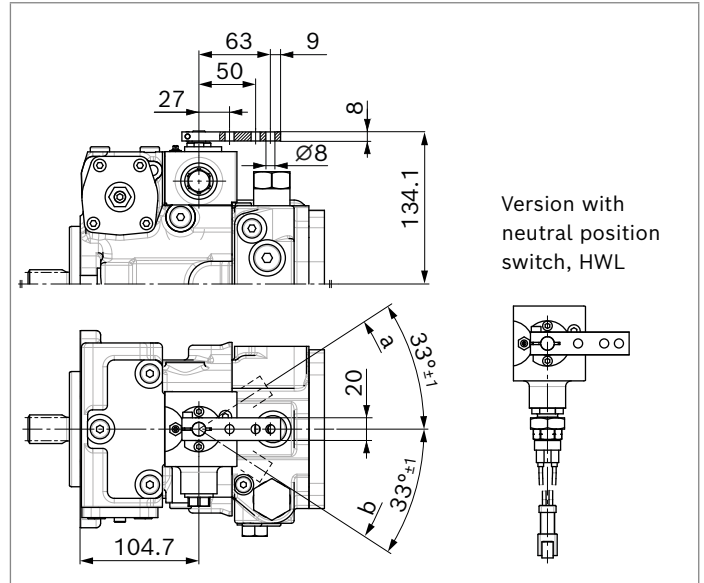

▼ **DG** – Hydraulic control, direct operated

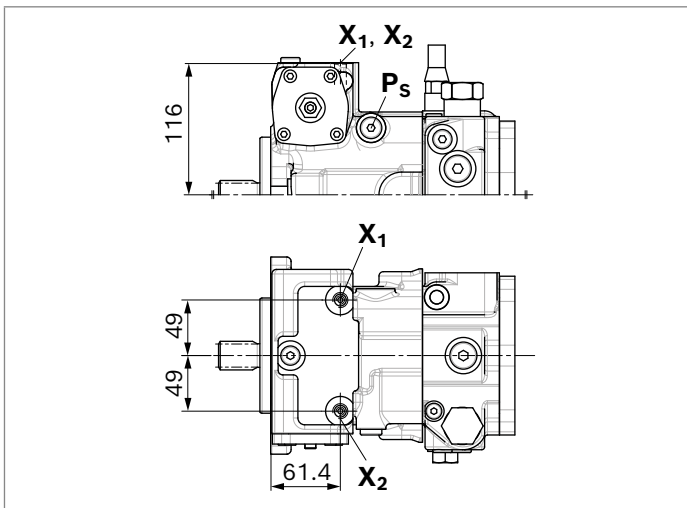

▼ **EZ** – Two-point control, electric

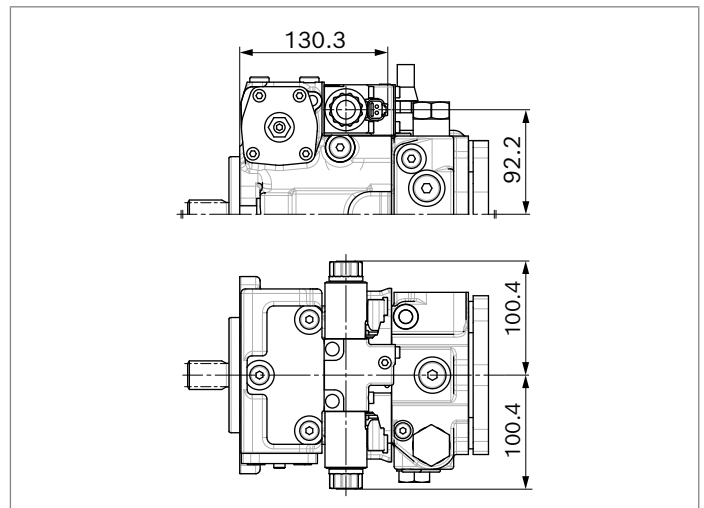

▼ **ET** – Electric control, direct operated

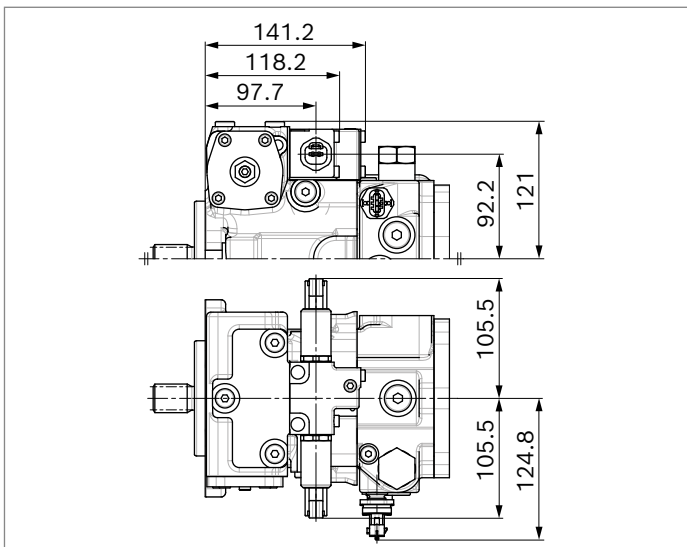

▼ **ED2** – Electric pressure controller

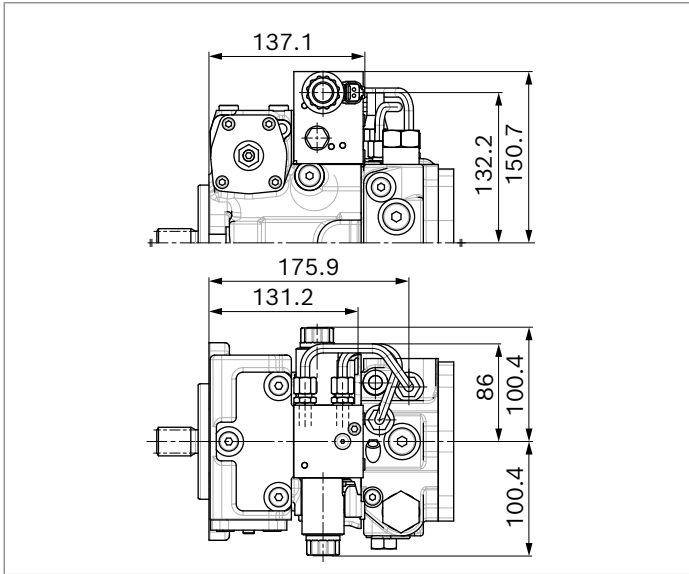

▼ **ED4** – Electric pressure controller

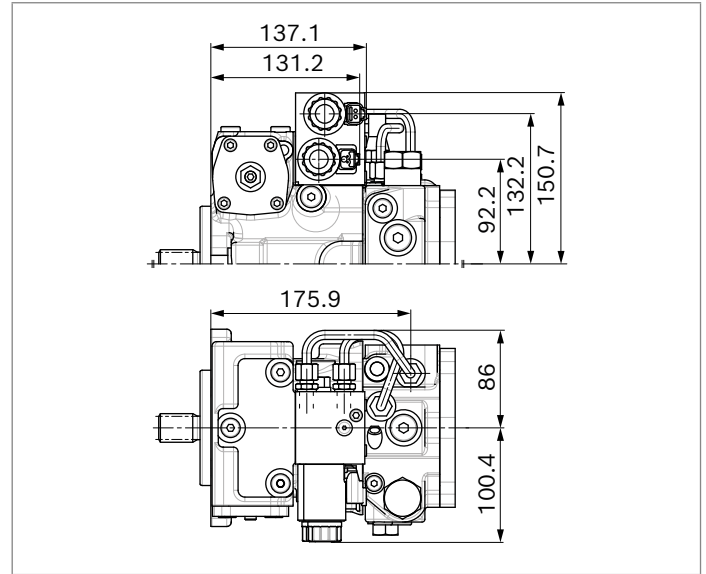

DA control valve

▼ **DA..2** – fixed setting

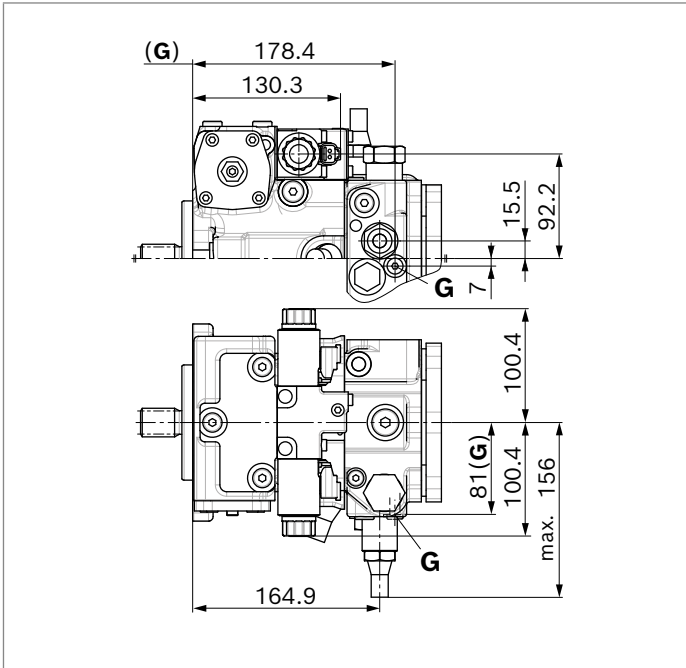

▼ **DA..3** – mechanically adjustable with position lever

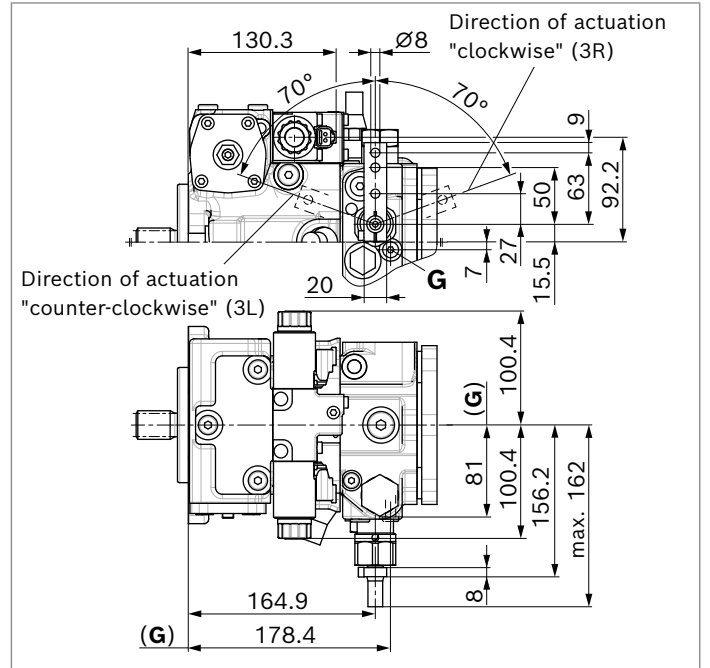

▼ **DA..7** – fixed setting and ports for pilot control device

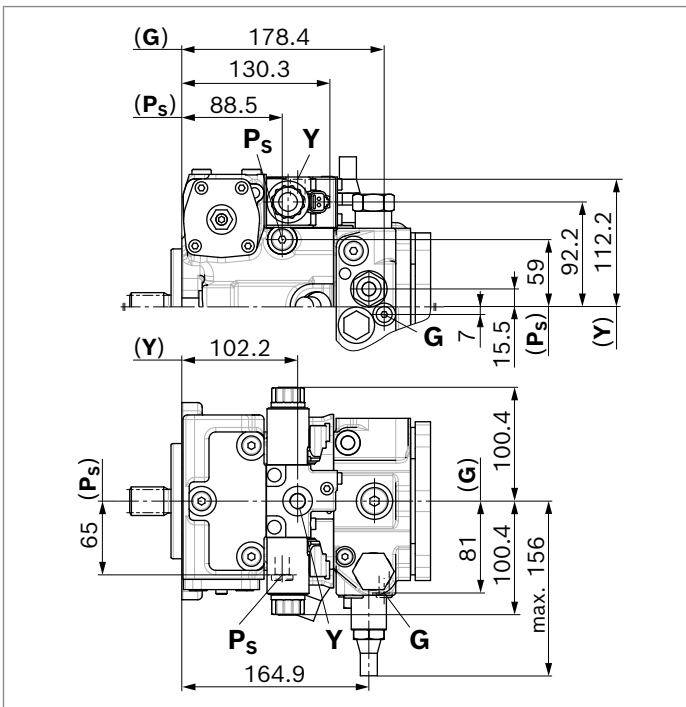

▼ **DA..8** – fixed setting and inch valve mounted

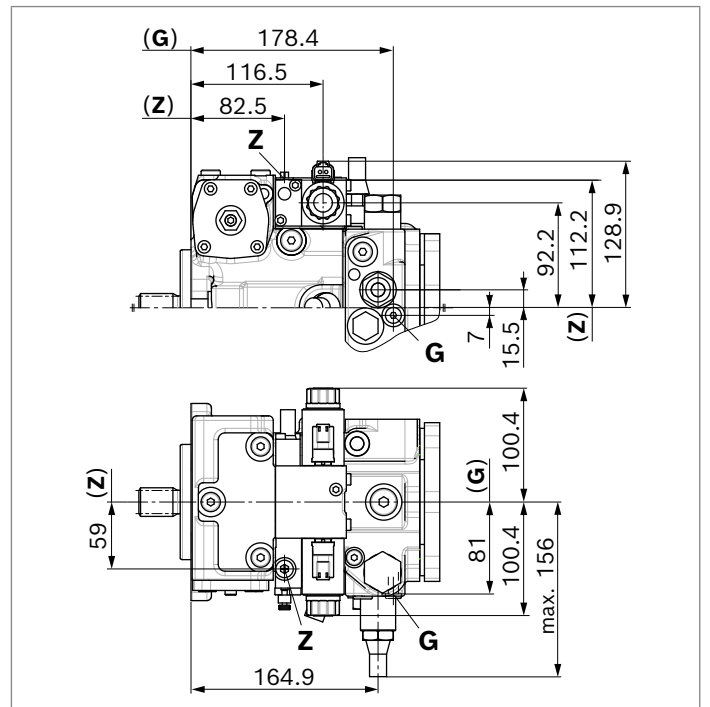

Dimensions, size 45

EP – Proportional control, electric

Standard: SAE working port **A** and **B**, same side left, suction port **S** bottom (10)

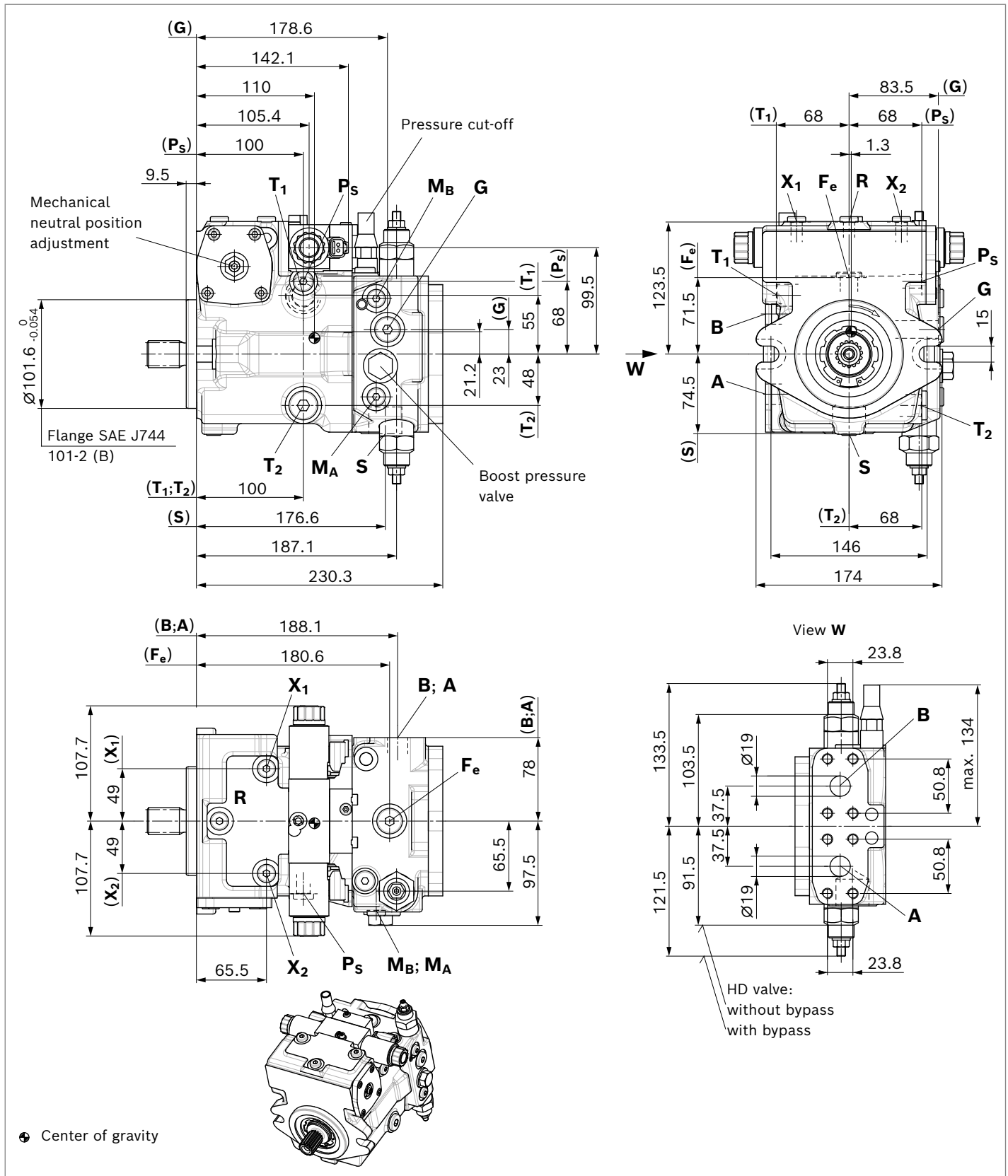

▼ Splined shaft ANSI B92.1a

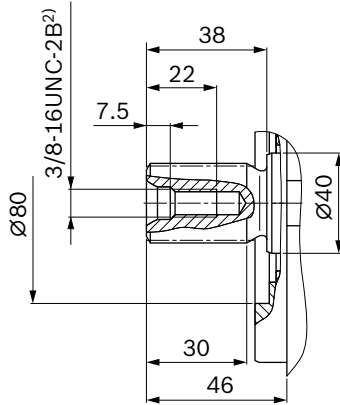
S – 1 in 15T 16/32DP¹⁾

▼ Splined shaft ANSI B92.1a

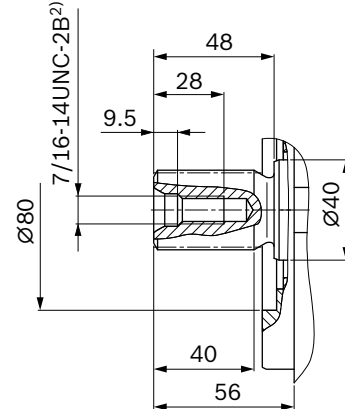
T – 1 1/4 in 14T 12/24DP¹⁾

Ports		Standard	Size	p_{\max} [bar] ³⁾	State ⁹⁾
A, B	Working port	SAEJ518 ⁴⁾	3/4 in	350	O
	Fastening thread	DIN 13	M10 × 1.5; 17 deep		
S	Suction port	DIN 3852 ⁷⁾	M33 × 2; 18 deep	5	O ⁵⁾
T₁	Drain port	DIN 3852 ⁷⁾	M22 × 1.5; 15 deep	3	O ⁶⁾
T₂	Drain port	DIN 3852 ⁷⁾	M22 × 1.5; 15 deep	3	X ⁶⁾
R	Air bleed port	DIN 3852 ⁷⁾	M12 × 1.5; 12 deep	3	X
X₁, X₂	Control pressure port (upstream of orifice)	DIN 3852 ⁷⁾	M12 × 1.5; 12 deep	40	X
X₃, X₄⁸⁾	Stroking chamber pressure port	DIN 3852 ⁷⁾	M10 × 1; 8 deep	40	X
G (F_a)	Boost pressure port inlet	DIN 3852 ⁷⁾	M18 × 1.5; 12 deep	40	X
G	Boost pressure port inlet (only DA control valve)	DIN 3852 ⁷⁾	M14 × 1.5; 12 deep	40	X
P_S	Pilot pressure port	DIN 3852 ⁷⁾	M14 × 1.5; 12 deep	40	X
Y	Pilot pressure port outlet (only DA...7)	DIN 3852 ⁷⁾	M14 × 1.5; 12 deep	40	O
M_A, M_B	Measuring port pressure A, B	DIN 3852 ⁷⁾	M12 × 1.5; 12 deep	350	X
F_e	Boost pressure port outlet	DIN 3852 ⁷⁾	M18 × 1.5; 12 deep	40	X
Y₁, Y₂	Pilot pressure port outlet (only HD)	DIN 3852 ⁷⁾	M14 × 1.5; 12 deep	40	O
Z	Pilot pressure port (inch signal only DA..8)	DIN 3852 ⁷⁾	M10 × 1; 8 deep	80	X

- 1) Involute spline according to ANSI B92.1a, 30° pressure angle, flat root, side fit, tolerance class 5
- 2) Thread according to ASME B1.1
- 3) Depending on the application, momentary pressure peaks can occur. Keep this in mind when selecting measuring devices and fittings.
- 4) Only dimensions according to SAE J518, metric fastening thread is a deviation from the standard.
- 5) Plugged for external boost pressure supply.

- 6) Depending on installation position, **T₁** or **T₂** must be connected (see also installation instructions on page 56).
- 7) The countersink can be deeper than specified in the standard. Ports designed for straight stud ends according to EN ISO 9974-2 type E
- 8) Optional, see page 49
- 9) O = Must be connected (comes plugged)
X = Plugged (in normal operation)

▼ **HD** – Proportional control, hydraulic, pilot-pressure related

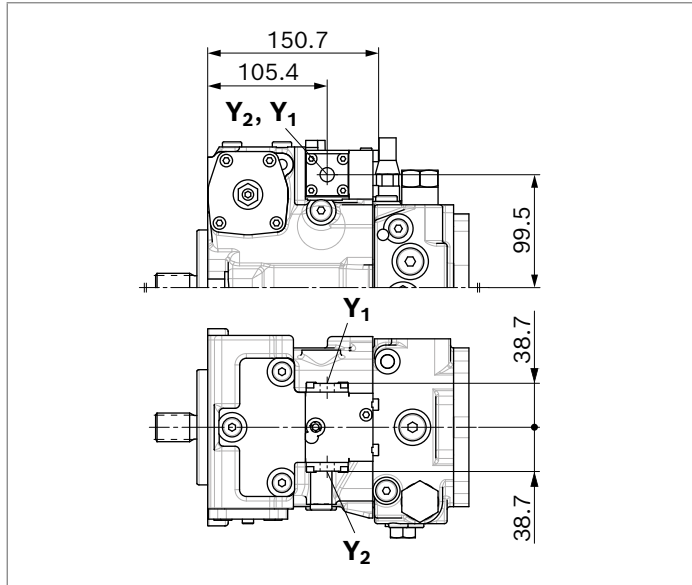

▼ **HW** – Proportional control, hydraulic, mechanical servo

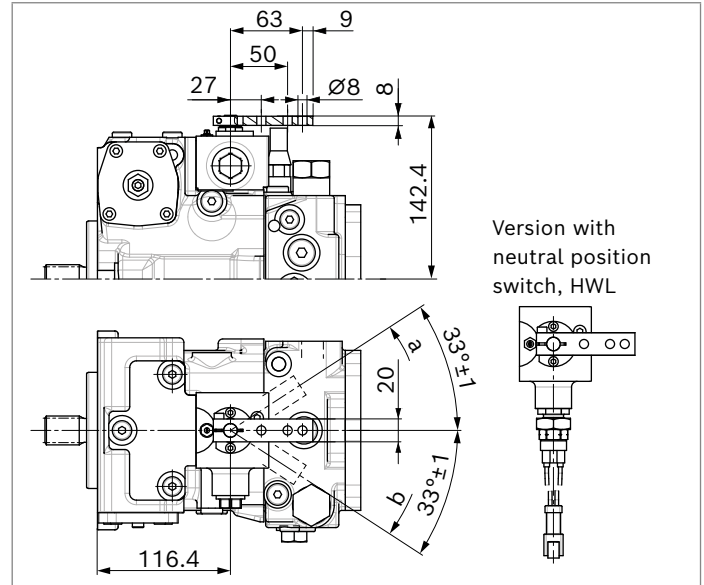

▼ **DG** – Hydraulic control, direct operated

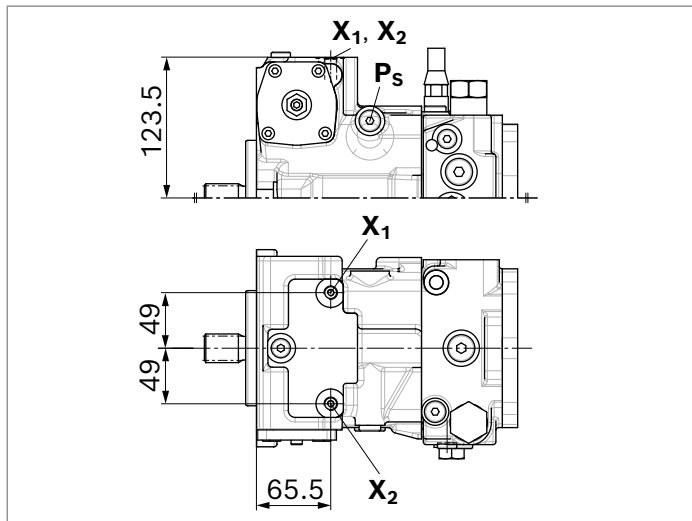

▼ **EZ** – Two-point control, electric

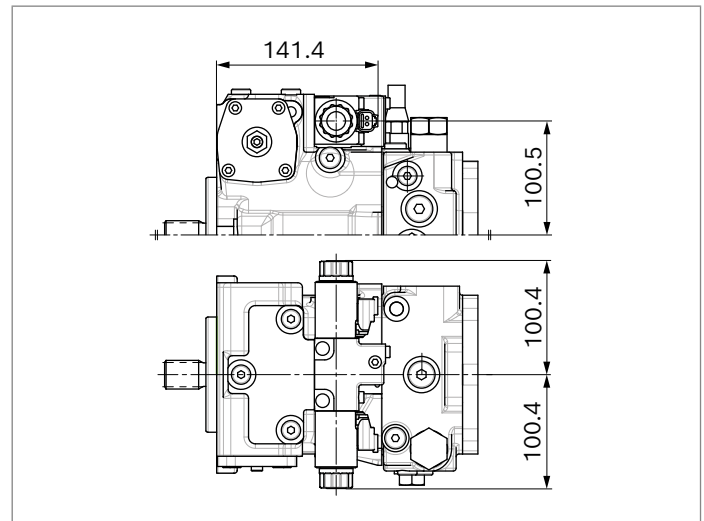

▼ **ET** – Electric control, direct operated

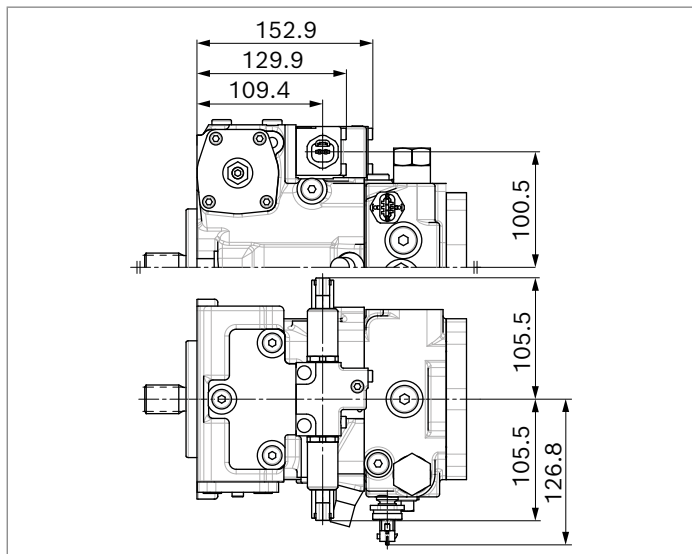

▼ **ED2** – Electric pressure controller

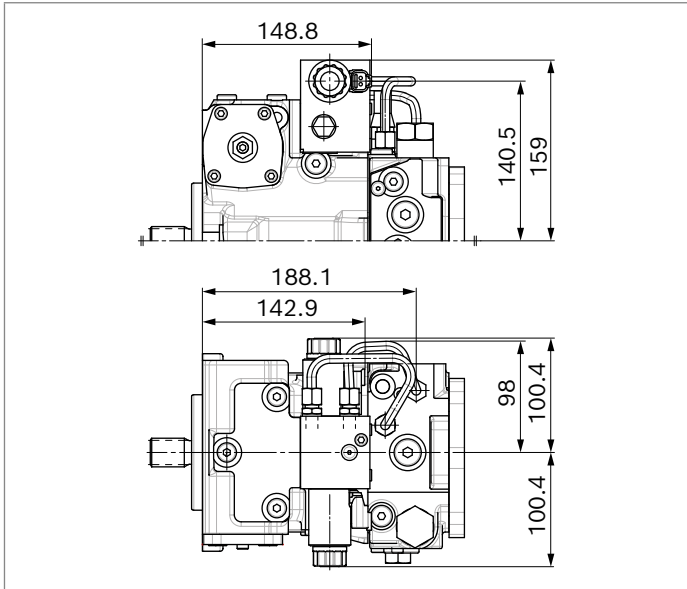

▼ **ED4** – Electric pressure controller

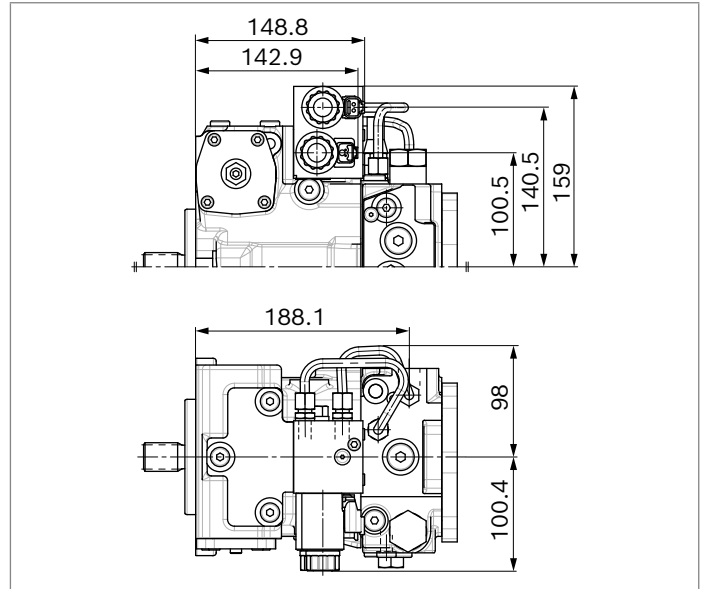

DA control valve

▼ **DA..2** – fixed setting

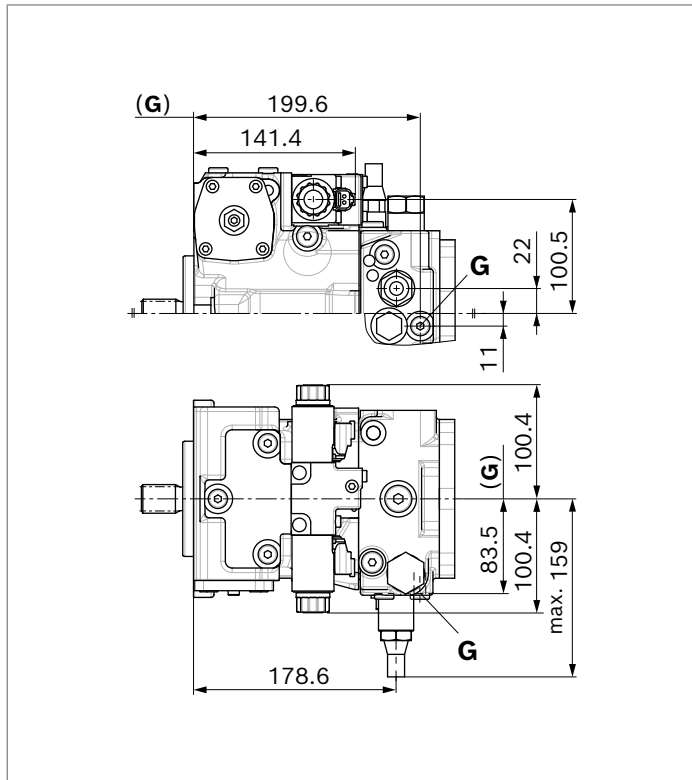

▼ **DA..3** – mechanically adjustable with position lever

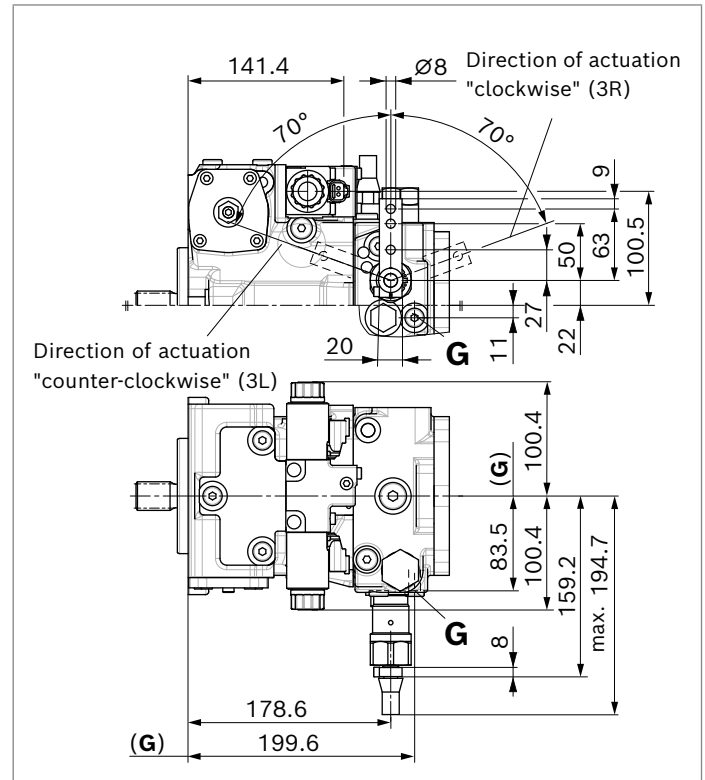

▼ **DA..7** – fixed setting and ports for pilot control device

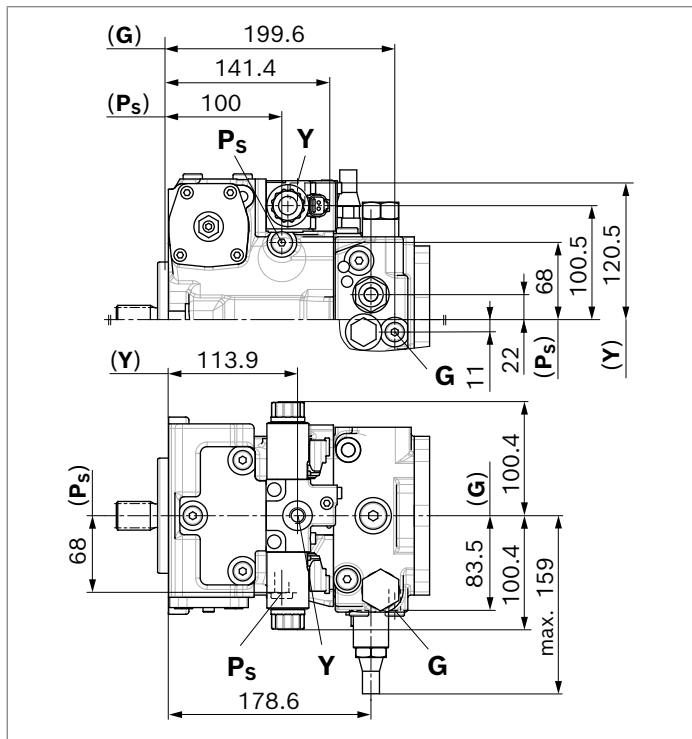

▼ **DA..8** – fixed setting and inch valve mounted

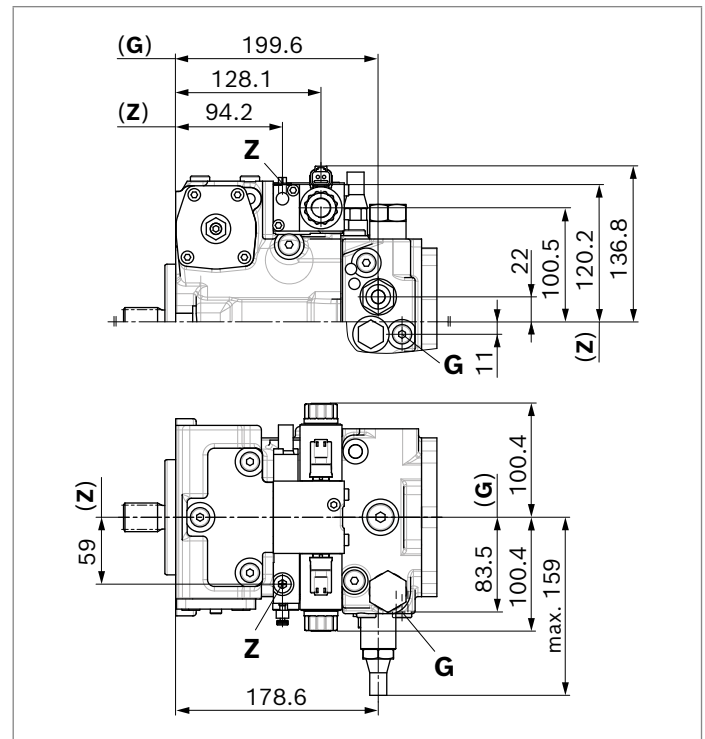

Dimensions, size 63

EP – Proportional control, electric

Standard: SAE working port **A** and **B**, same side left, suction port **S** bottom (10)

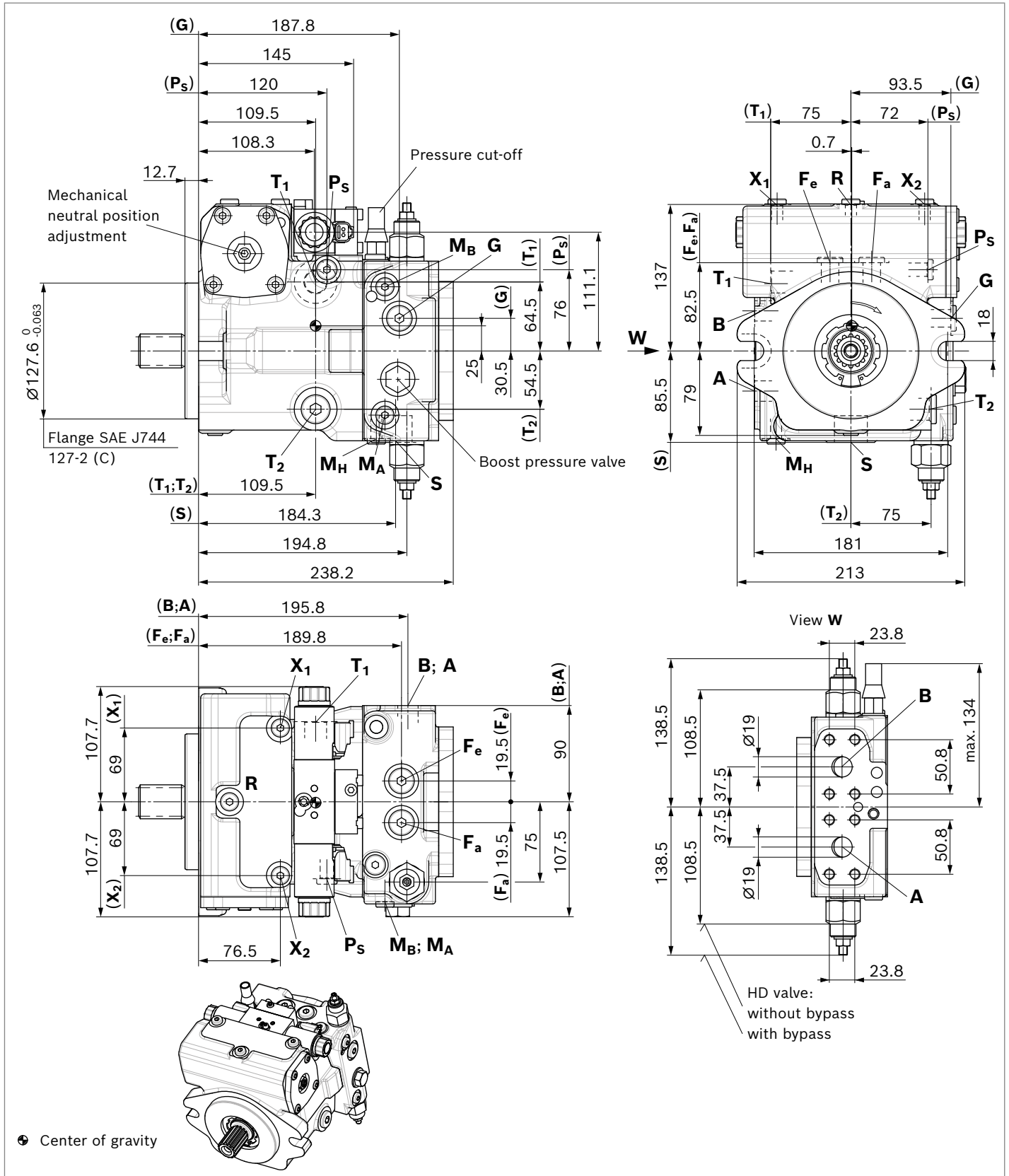

▼ **Splined shaft ANSI B92.1a**

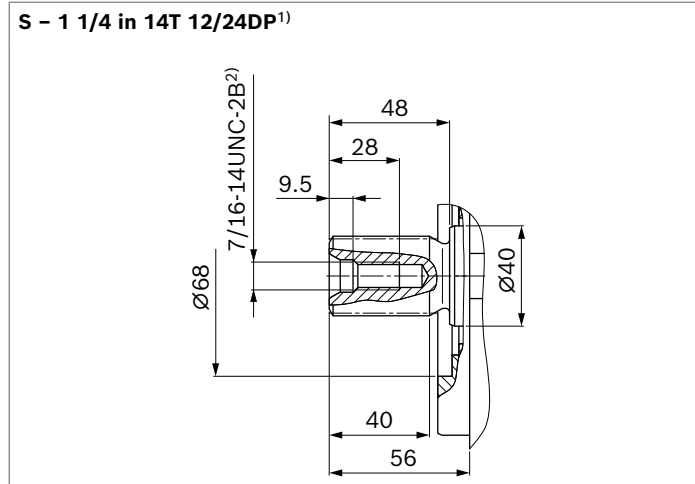

▼ **Splined shaft ANSI B92.1a**

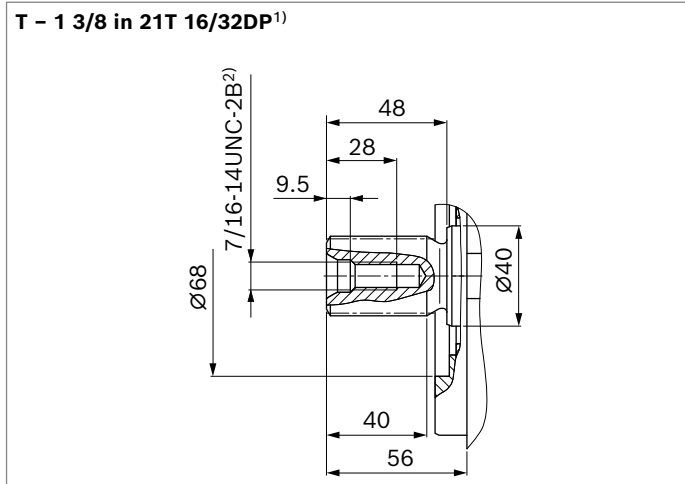

Ports	Standard	Size	p_{max} [bar] ³⁾	State ⁹⁾
A, B Working port Fastening thread	SAEJ518 ⁴⁾ DIN 13	3/4 in M10 × 1.5; 17 deep	350	O
S Suction port	DIN 3852 ⁷⁾	M33 × 2; 18 deep	5	O ⁵⁾
T₁ Drain port	DIN 3852 ⁷⁾	M22 × 1.5; 15 deep	3	O ⁶⁾
T₂ Drain port	DIN 3852 ⁷⁾	M22 × 1.5; 15 deep	3	X ⁶⁾
R Air bleed port	DIN 3852 ⁷⁾	M12 × 1.5; 12 deep	3	X
X₁, X₂ Control pressure port (upstream of orifice)	DIN 3852 ⁷⁾	M12 × 1.5; 12 deep	40	X
X₃, X₄⁸⁾ Stroking chamber pressure port	DIN 3852 ⁷⁾	M12 × 1.5; 12 deep	40	X
G Boost pressure port inlet	DIN 3852 ⁷⁾	M18 × 1.5; 12 deep	40	X
P_s Pilot pressure port	DIN 3852 ⁷⁾	M14 × 1.5; 12 deep	40	X
Y Pilot pressure port outlet (only DA..7)	DIN 3852 ⁷⁾	M14 × 1.5; 12 deep	40	O
M_A, M_B Measuring port pressure A, B	DIN 3852 ⁷⁾	M12 × 1.5; 12 deep	350	X
M_H Measuring port, high pressure	DIN 3852 ⁷⁾	M12 × 1.5; 12 deep	350	X
F_a Boost pressure port inlet	DIN 3852 ⁷⁾	M18 × 1.5; 12 deep	40	X
F_e Boost pressure port outlet	DIN 3852 ⁷⁾	M18 × 1.5; 12 deep	40	X
Y₁, Y₂ Pilot pressure port outlet (only HD)	DIN 3852 ⁷⁾	M14 × 1.5; 12 deep	40	O
Z Pilot pressure port (inch signal only DA..8)	DIN 3852 ⁷⁾	M10 × 1; 8 deep	80	X

1) Involute spline according to ANSI B92.1a, 30° pressure angle, flat root, side fit, tolerance class 5
 2) Thread according to ASME B1.1
 3) Depending on the application, momentary pressure peaks can occur. Keep this in mind when selecting measuring devices and fittings.
 4) Only dimensions according to SAE J518, metric fastening thread is a deviation from the standard.
 5) Plugged for external boost pressure supply.

6) Depending on installation position, **T₁** or **T₂** must be connected (see also installation instructions on page 56).
 7) The countersink can be deeper than specified in the standard. Ports designed for straight stud ends according to EN ISO 9974-2 type E
 8) Optional, see page 49
 9) O = Must be connected (comes plugged)
 X = Plugged (in normal operation)

▼ **HD** – Proportional control, hydraulic, pilot-pressure related

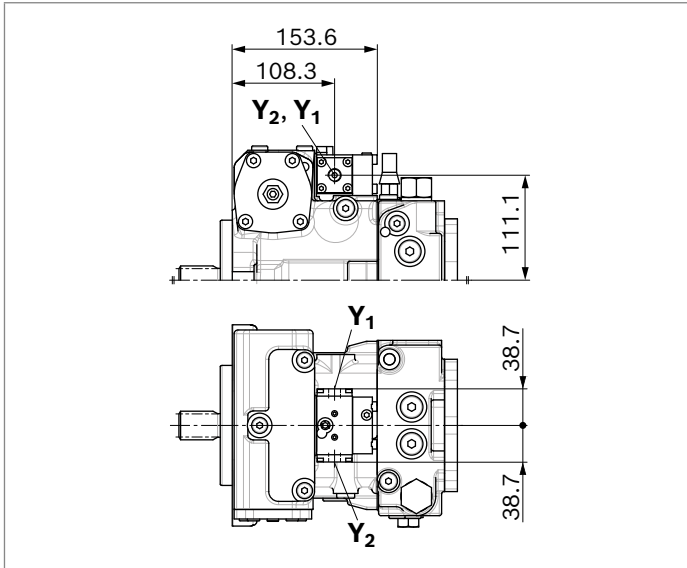

▼ **HW** – Proportional control, hydraulic, mechanical servo

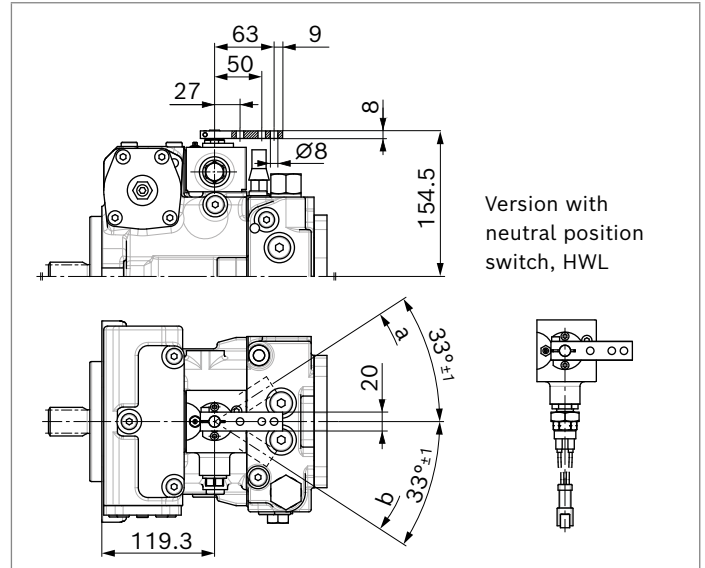

▼ **DG** – Hydraulic control, direct operated

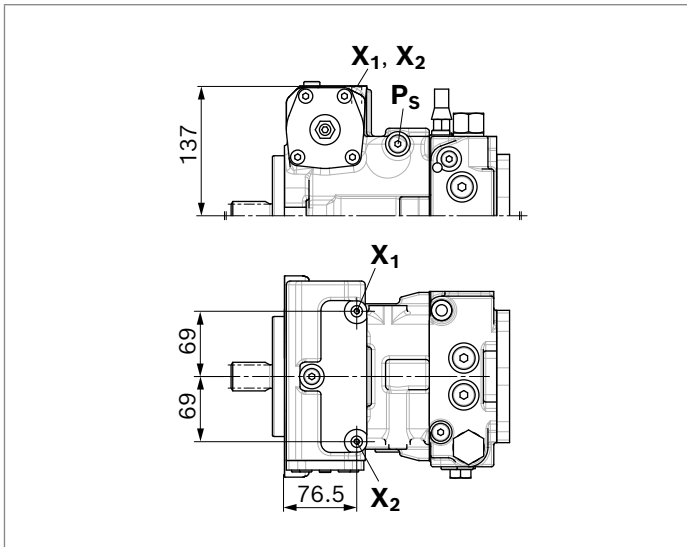

▼ **EZ** – Two-point control, electric

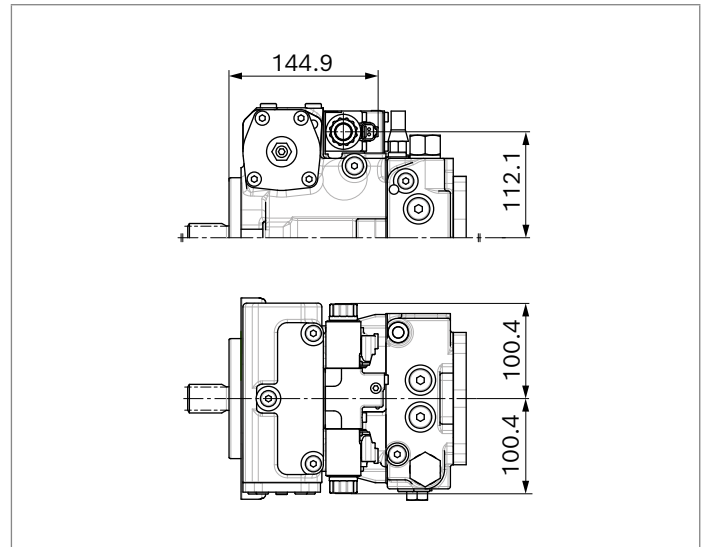

▼ **ED2** – Electric pressure controller

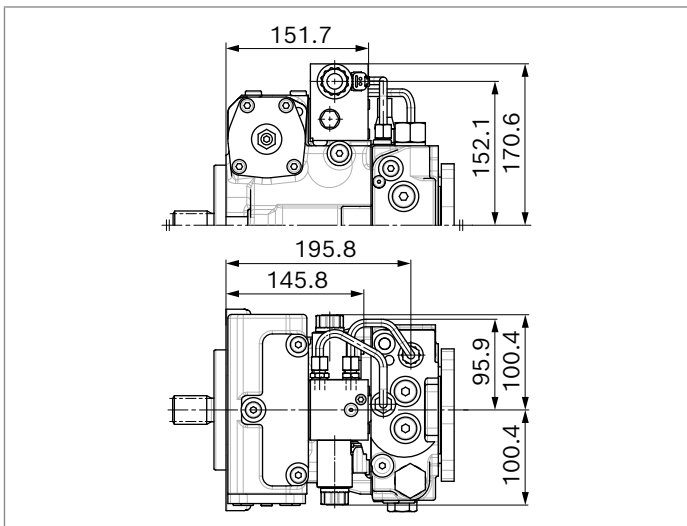

▼ **ED4** – Electric pressure controller

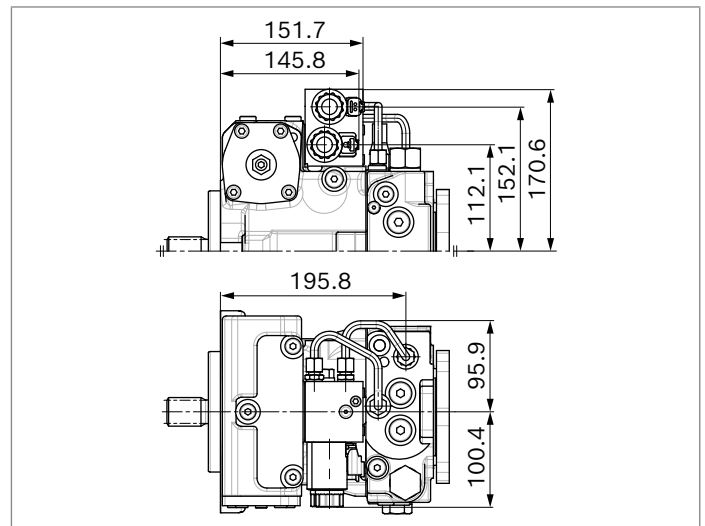

DA control valve

▼ **DA..2** – fixed setting

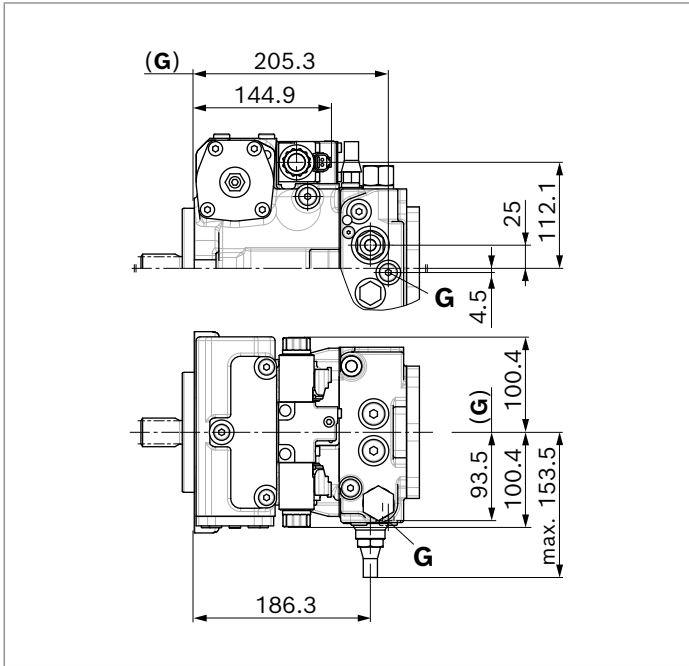

▼ **DA..3** – mechanically adjustable with position lever

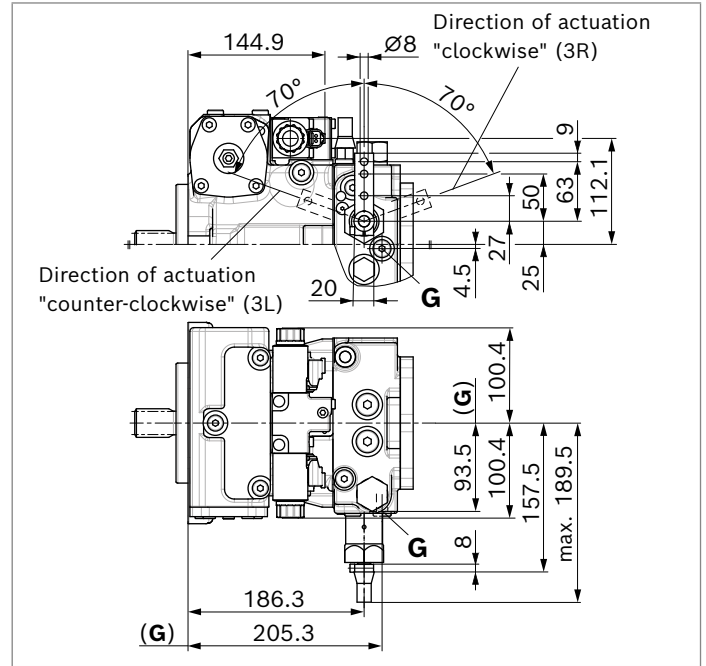

▼ **DA..7** – fixed setting and ports for pilot control device

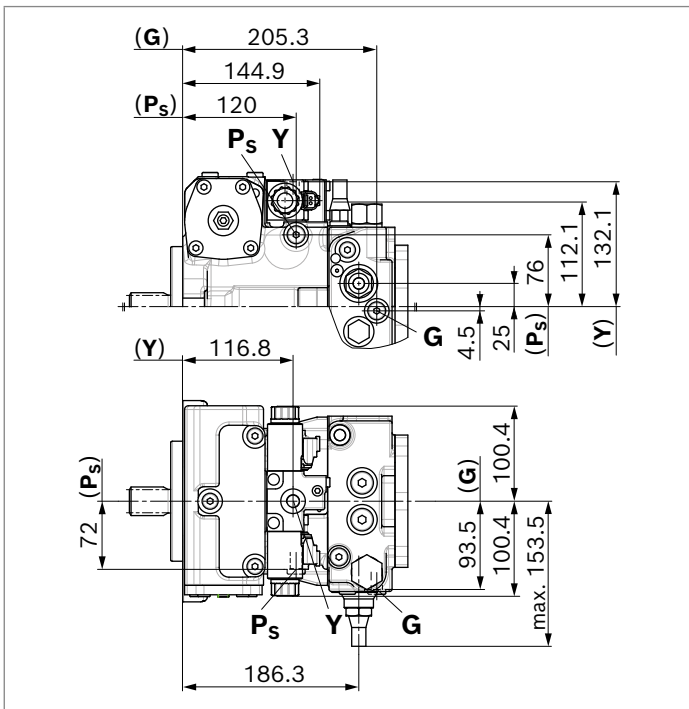

▼ **DA..8** – fixed setting and inch valve mounted

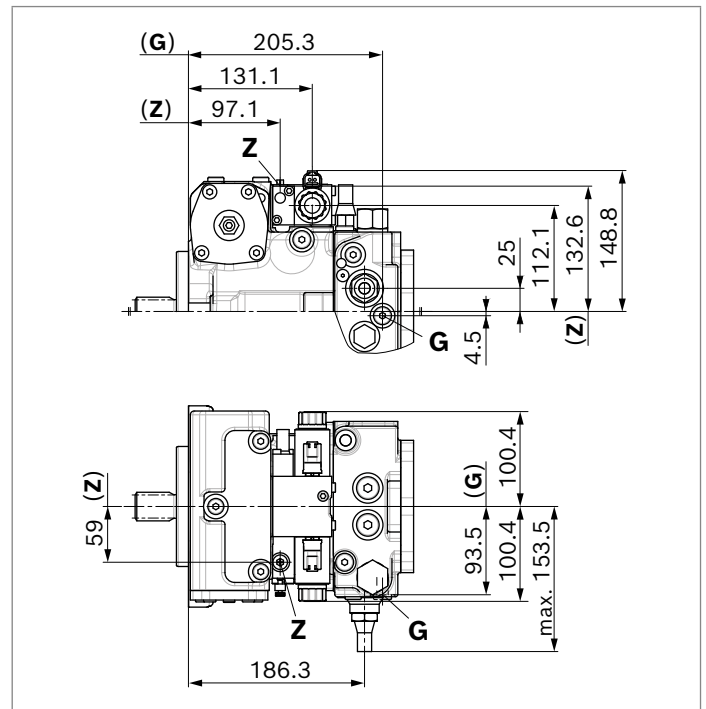

Dimensions, through drive

Flange SAE J744	Hub for splined shaft ¹⁾	18	28	45	63	Code
Without through drive		•	•	•	•	00
82-2 (A)	5/8 in 9T 16/32DP	•	•	•	•	01

▼ **N00** – without boost pump, without through drive / **F00** – with boost pump, without through drive

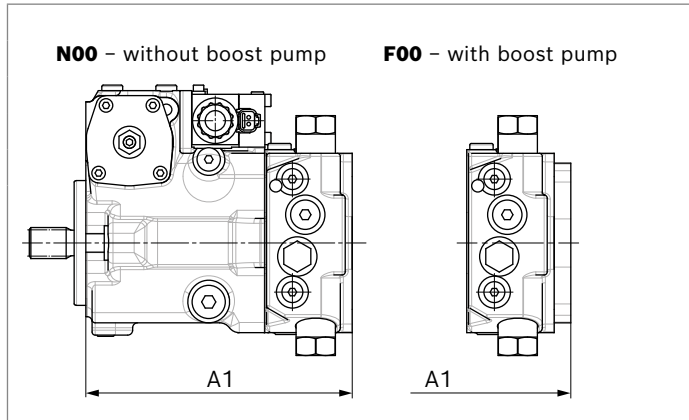

NG	A1 (N00)	A1 (F00)
18	169.4	169.4
28	201.7	215.3
45	216.8	230.5
63	224.5	238.2

▼ **F01/K01**⁵⁾

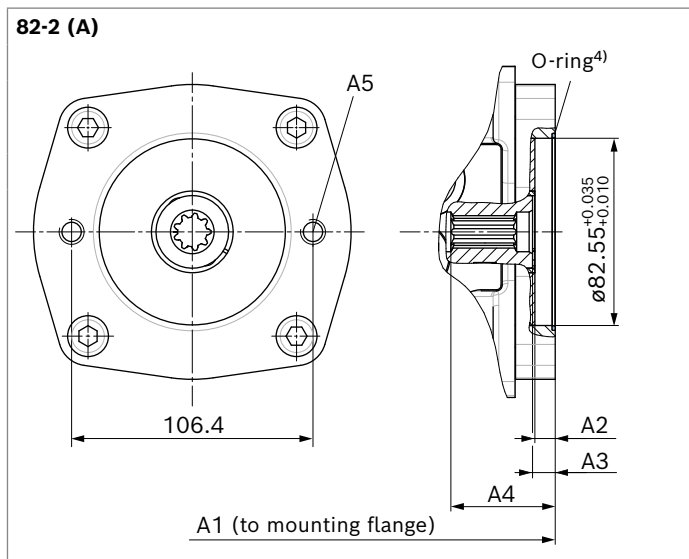

NG	A1	A2 ²⁾	A3	A4	A5 ³⁾
18	178.4	min. 8.8	9	32	M10 × 1.5; 13 deep
28	219.2	min. 8.8	9	35.7	
45	234.5	min. 8.8	9	46	
63	242.2	min. 8.8	9	45	

1) Involute spline according to ANSI B92.1a, 30° pressure angle, flat root, side fit, tolerance class 5
 2) According to SAE J744
 3) Thread according to DIN 13
 4) O-ring included in the scope of delivery
 5) Please state in plain text whether the 2-hole horizontal or the 2-hole vertical version is used.

Flange SAE J744	Hub for splined shaft ¹⁾	18	28	45	63	Code
82-2 (A)	3/4 in 11T16/32DP	-	●	●	●	52
101-2 (B)	7/8 in 13T 16/32DP	●	●	●	●	02
	1 in 15T 16/32DP	-	●	●	●	04

F52/K52⁵⁾

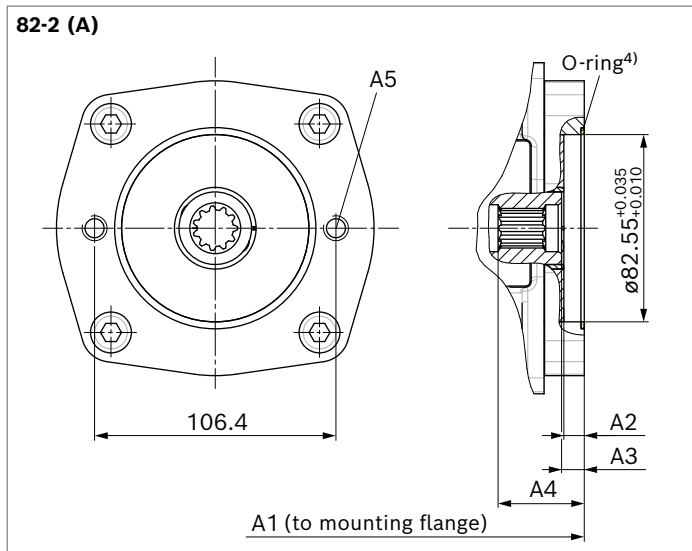

NG	A1	A2 ²⁾	A3	A4	A5 ³⁾
28	219.1	min. 8.8	9	37.6	M10 × 1.5; 13 deep
45	234.5	min. 8.8	9	38	
63	242	min. 8.8	9	37	

▼ F02/K02; F04/K04⁵⁾

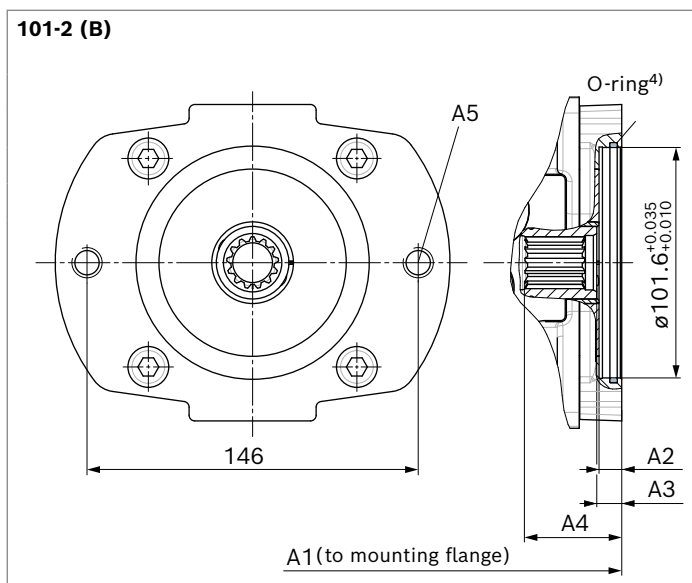

NG	A1	A2 ²⁾	A3	A4 (02)	A4 (04)	A5 ³⁾
18	187.4	min. 8.8	10	39.7	-	M12 × 1.75; 18 deep
28	220.2	min. 8.8	10	43.7	43.7	M12 × 1.75; 18.5 deep
45	235.5	min. 8.8	10	47.6	50.0	
63	243.2	min. 8.8	10	51.9	43.7	

- 1) Involute spline according to ANSI B92.1a, 30° pressure angle, flat root, side fit, tolerance class 5
- 2) According to SAE J744
- 3) Thread according to DIN 13
- 4) O-ring included in the scope of delivery
- 5) Please state in plain text whether the 2-hole horizontal or the 2-hole vertical version is used.

Flange SAE J744	Hub for splined shaft ¹⁾	18	28	45	63	Code
127-2 (C)	1 1/4 in 14T 12/24DP	-	-	-	●	07

▼ **F07/K07⁵⁾**

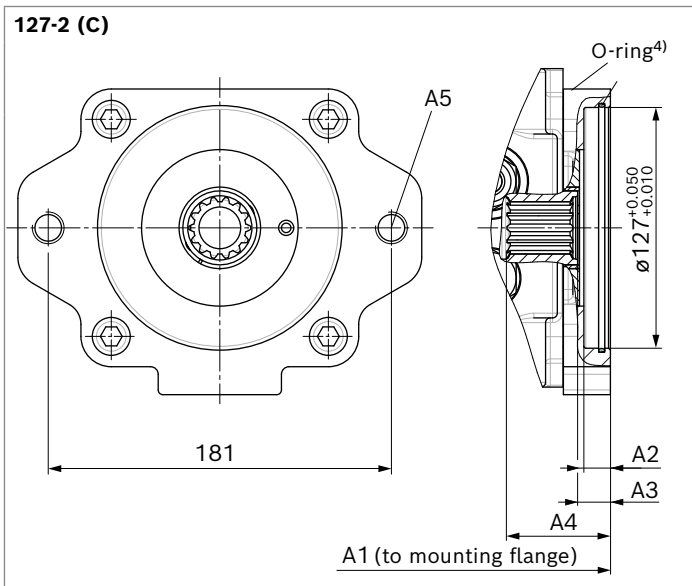

NG	A1	A2 ²⁾	A3	A4	A5 ³⁾
63	249.5	min. 8.8	14	53.9	M16 × 2; 24.8 deep

- 1) Involute spline according to ANSI B92.1a, 30° pressure angle, flat root, side fit, tolerance class 5
- 2) According to SAE J744
- 3) Thread according to DIN 13
- 4) O-ring included in the scope of delivery
- 5) Please state in plain text whether the 2-hole horizontal or the 2-hole vertical version is used.

Overview of mounting options

Through drive ¹⁾			Mounting option – 2nd pump						
Flange	Hub for splined shaft	Code	A10VG/10 NG (shaft)	A4VG/32 NG (shaft)	A10V(S) O/3X NG (shaft)	A10V(S) O/5X NG (shaft)	A11VO/1 NG (shaft)	A1VO/10	External gear pump ²⁾
82-2 (A)	5/8 in	F/K01	–	–	18 (U)	10, 18 (U)	–	–	AZPF, AZPS NG4 ... 28 AZPW NG5 ... 22
	3/4 in	F/K52	–	–	–	–	–	–	AZPF NG4 ... 28
101-2 (B)	7/8 in	F/K02	18 (S)	–	28 (S) 45 (U)	28 (S) 45 (U)	–	35 (S4)	AZPN-11 NG20 ... 25 AZPG-22 NG28 ... 100
	1 in	F/K04	28, 45 (S)	28 (S)	45 (S)	45 (S) 60, 63 (U)	40 (S)	35 (S5)	–
127-2 (C)	1 1/4 in	F/K09	63 (S)	40, 56 (S)	–	–	–	–	–

Notice

The mounting options listed only apply for drive shaft versions with undercut. Please contact us for drive shafts without undercut.

1) Availability of the individual sizes, see type code on page 4.

2) Bosch Rexroth recommends special versions of the gear pumps.
 Please contact us.

Combination pumps A10VG + A10VG**Total length A**

A10VG 1st pump	A10VG 2nd pump ¹⁾			
	NG18	NG28	NG45	NG63
NG18	356.8	–	–	–
NG28	389.6	435.5	–	–
NG45	404.9	450.8	466.0	–
NG63	412.6	458.5	473.7	487.7

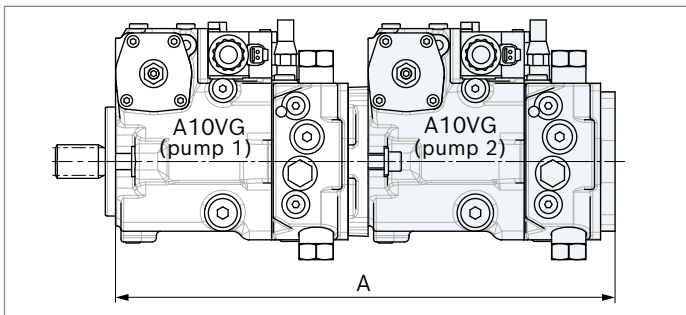

By using combination pumps, it is possible to have independent circuits without the need for splitter gearboxes. When ordering combination pumps, the type designations of the 1st and 2nd pumps must be linked by a "+".

Order example:

**A10VG45EP4D1/10R-NTC10F043SP +
A10VG45EP4D1/10R-NSC10F003SP**

For combination pumps, we recommend a support. Without additional support from the second pump, calculation of the mounting flange is necessary for every load case, please contact us.

Notice

- ▶ The combination pump type code is shown in shortened form in the order confirmation.
- ▶ The permissible through-drive torques are to be observed (see page 9).

1) 2. pump without through drive and with boost pump, F00

High-pressure relief valves

The two high-pressure relief valves protect the hydrostatic gear (pump and motor) from overloading. They limit the maximum pressure in the respective high-pressure line and serve simultaneously as boost valves.

High-pressure relief valves are not working valves and are only suitable for pressure peaks or high rates of pressure change.

Setting ranges

High-pressure relief valve, direct operated	Differential pressure setting Δp_{HD}
Setting range valve 3, 5	320 bar
Δp_{HD} 250 ... 320 bar (see type code)	300 bar
	270 bar
Setting range valve 4, 6	250 bar
Δp_{HD} 100 ... 250 bar (see type code)	230 bar
	200 bar
	150 bar
	100 bar

Settings on high-pressure relief valve A and B

Differential pressure setting	$\Delta p_{HD} = \dots$ bar
Cracking pressure of the HD valve (at q_{V1}) ($p_{max} = \Delta p_{HD} + p_{Sp}$)	$p_{max} = \dots$ bar

- ▶ The valve settings are made at $n = 1000$ rpm and at $V_{g \max}$ (q_{V1}). There may be deviations in the cracking pressures with other operating parameters.
- ▶ When ordering, state the differential pressure setting Δp_{HD} in the plain text.

▼ Circuit diagram

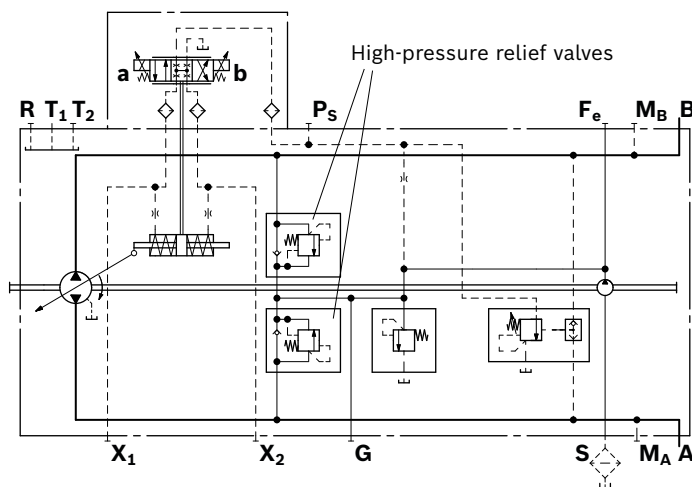

Example: Δp drive design = 270 bar ($p_{A, B} - p_{Sp}$)

Working pressure $p_{A, B}$	-	Boost pressure p_{Sp}	+	Safety	=	Differential pressure Δp_{HD}
290 bar	-	20 bar	+	30 bar	=	300 bar

- ▶ Cracking pressure of the HD valve (at q_{V1}):

$$p_{max} = 320 \text{ bar } (p_{max} = \Delta p_{HD} + p_{Sp})$$

▼ Setting diagram

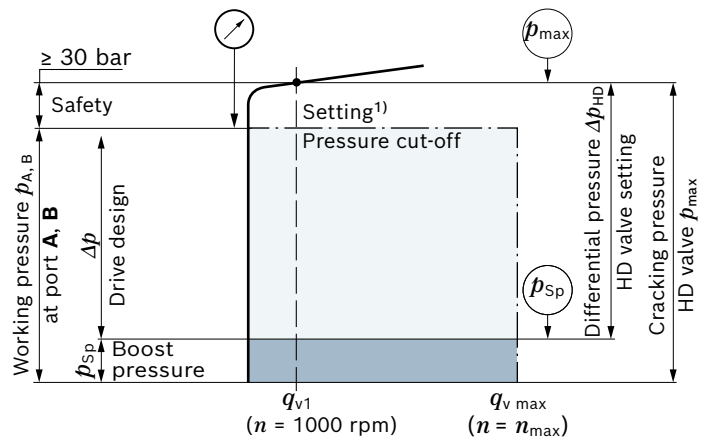

Key	
HD valve	High-pressure relief valve
Cracking pressure HD valve p_{max}	When the set pressure value is reached, the HD valve opens and thus protects the hydrostatic gear (pump and motor) from overloading
Differential pressure HD valve Δp_{HD}	Cracking pressure HD valve (abs.) minus the boost pressure setting
Working pressure $p_{A, B}$	The total design of the customer machine is based on this pressure value. It comprises the boost pressure setting and the Δp drive design.
Δp drive design	Differential pressure value determining the available torque at the hydraulic motor ($p_{A, B} - p_{Sp}$).
Boost pressure p_{Sp}	Boost pressure setting of the low-pressure valve
Safety	Required distance between working pressure (and/or pressure cut-off) and cracking pressure of the high-pressure relief valve to ensure the intended function of the high-pressure relief valve.

Notice

Upon response of the high-pressure relief valve, the permissible temperature and viscosity must be complied with.

1) Omitted with version without pressure cut-off

Bypass function

A connection between the two high-pressure passages **A** and **B** can be established using the bypass function (e.g. for machine towing).

► **Towing speed**

The maximum towing speed depends on the gear ratio in the vehicle and must be calculated by the vehicle manufacturer. The corresponding flow of $q_v = 30$ l/min may not be exceeded.

► **Towing distance**

Only tow the vehicle out of the immediate danger zone. For further information on the bypass function, see the instruction manual.

Notice

The bypass function is not illustrated in the circuit diagrams.

Pressure cut-off

The pressure cut-off is a pressure control which, after reaching the set pressure, adjusts the displacement of the pump back to $V_{g \text{ min}}$.

This valve prevents the operation of the high-pressure relief valves when accelerating or decelerating.

The high-pressure relief valves protect against the pressure peaks which occur during fast swiveling of the swashplate and limit the maximum pressure in the system.

The setting range of the pressure cut-off may be anywhere within the entire working pressure range. However, it must at least be set 30 bar lower than the setting value of the high-pressure relief valves (see setting diagram, page 46).

The function of the pressure cut-off in combination with a DG control is described on page 17.

Please state the setting value of the pressure cut-off in plain text when ordering.

▼ **Circuit diagram with pressure cut-off**
Electric control, EP_D

Sizes 28 and 45

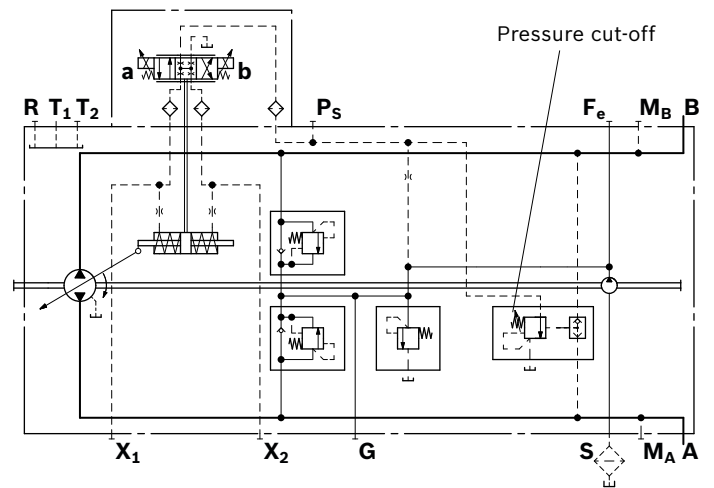

Size 63

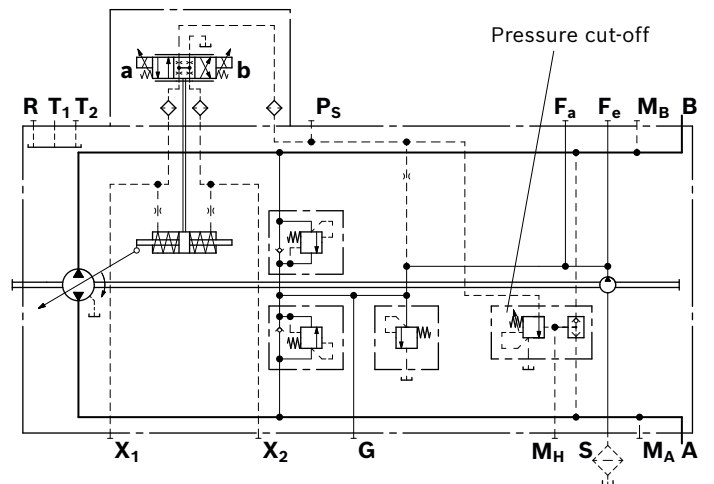

Mechanical stroke limiter

The mechanical stroke limiter is an auxiliary function allowing the maximum displacement of the pump to be steplessly reduced, regardless of the control module used. By means of two threaded pins, the stroke of the stroking piston and thus the maximum swivel angle of the pump can be limited.

Notice

Threaded pins are mounted from the inside (screw-out protection) and can no longer be removed from the outside.

Dimensions

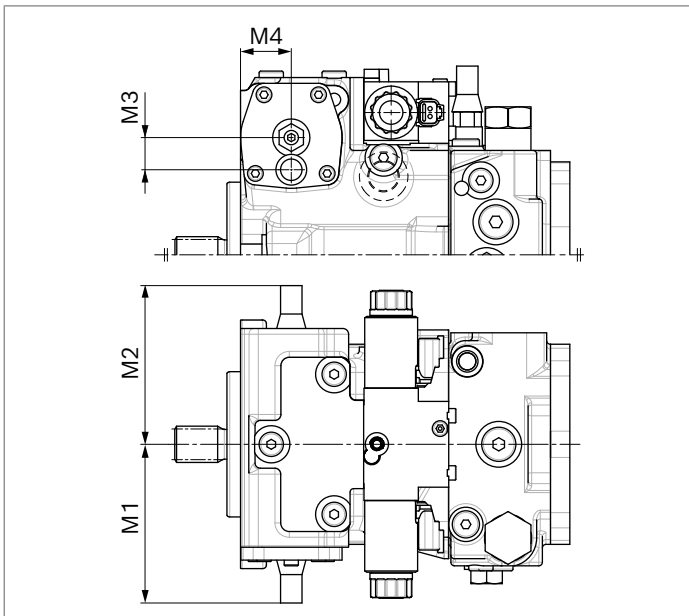

NG	M1	M2	M3	M4
18	max. 107	max. 109	18	42.1
28	max. 104.5	max. 108	21.5	35
45	max. 113	max. 113	22.5	35.5
63	max. 134.5	max. 136.5	26.5	43

▼ Circuit diagram sizes 28 and 45

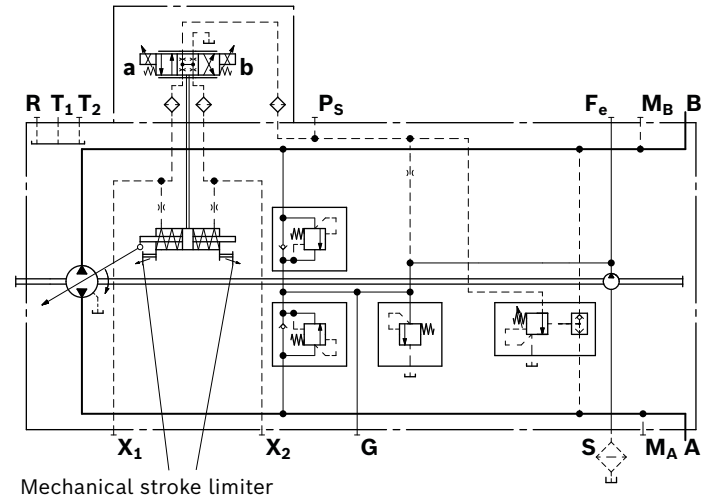

Mechanical stroke limiter

Stroking chamber pressure port X3 and X4

Dimensions

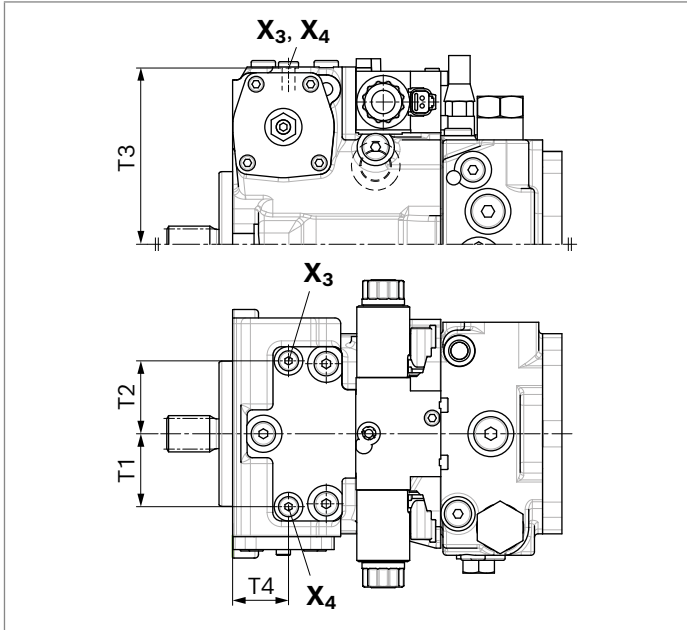

▼ Circuit diagram size 63

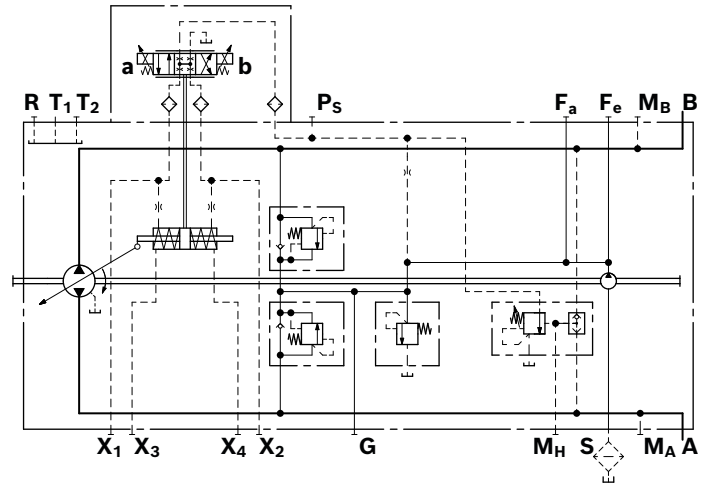

NG	T1	T2	T3	T4
28	51.5	51.5	116	35
45	51	51	123.7	39.1
63	69	69	137	49.5

NG	Ports	Standard ¹⁾	Size	p_{max} [bar] ²⁾	State ³⁾
28, 45	X3, X4	DIN 3852	M10 × 1; 8 deep	40	X
63	X3, X4	DIN 3852	M12 × 1.5; 12 deep	40	X

- 1) The countersink may be deeper than specified in the standard. Ports designed for straight stud ends according to EN ISO 9974-2 type E.
- 2) Depending on the application, momentary pressure peaks can occur. Keep this in mind when selecting measuring devices and fittings.
- 3) X = Plugged (in normal operation)

Measuring ports M_A , M_B , M_H

The measuring ports M_A , M_B and M_H are designed according to DIN 3852 and designed for straight stud ends according to EN ISO 9974-2 type E. The countersink may, however, be deeper than specified in the standard.

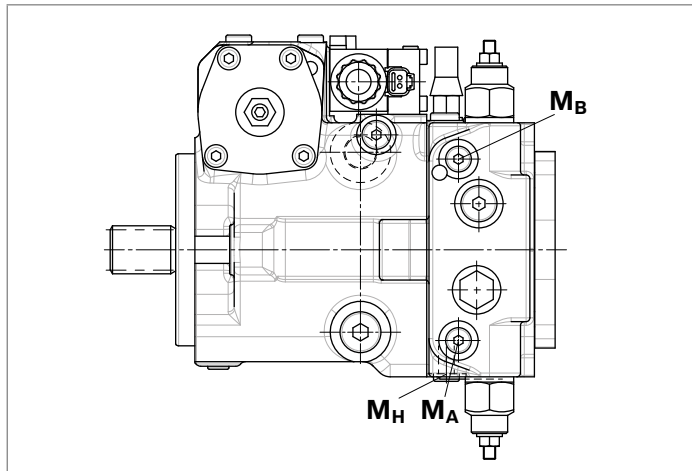

Countersink of the measuring ports M_A , M_B and M_H ¹⁾

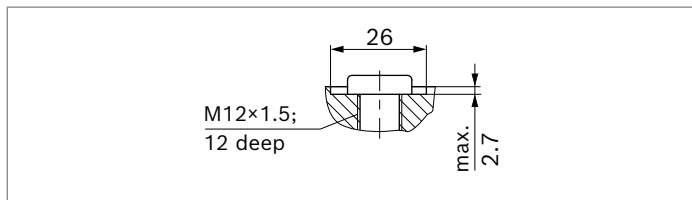

Circuit diagram sizes 28 and 45

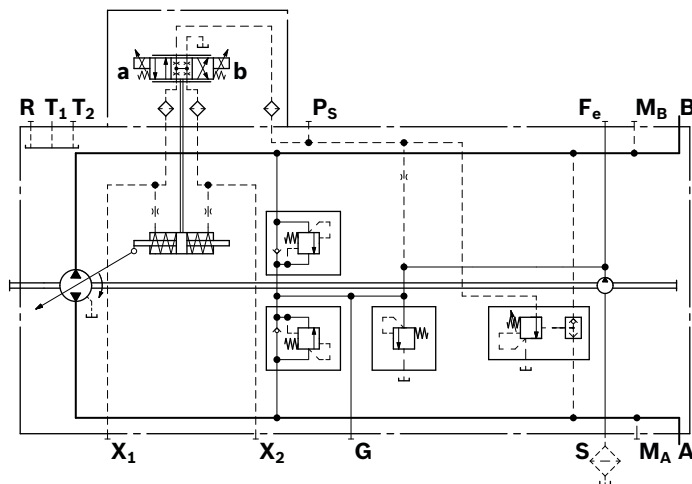

Circuit diagram size 63

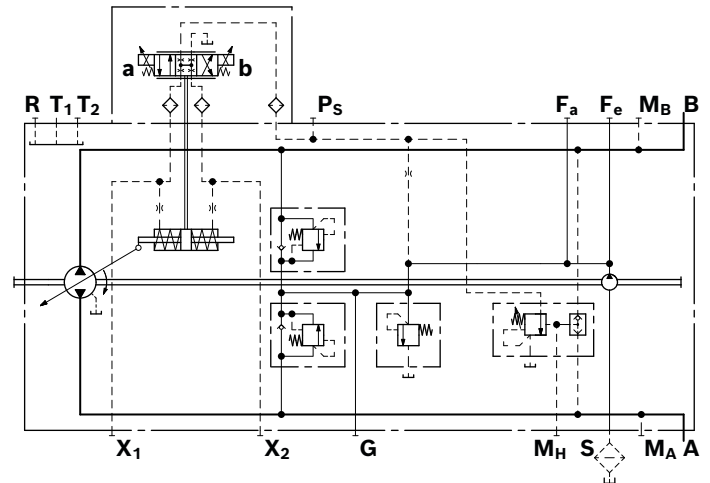

Notice

In connection with the ET control, a version with pressure sensors is required to be able to realize the preferred control of the unit by means of BODAS eDA (data sheet 95315).

One prerequisite for the combination with pressure sensors is a port plate version with M_A/M_B according to ISO 6149 M14 × 1.5. This design is only available for selected port plates, please contact us.

For information on the pressure sensor PR4 refer to data sheet 95156.

Measuring ports	Standard ¹⁾	NG18 ... 45	NG63	p_{max} [bar] ²⁾	State ³⁾
M_A Measuring port pressure A	DIN 3852	M12 × 1.5; 12 deep	M12 × 1.5; 12 deep	350	X
M_B Measuring port pressure B	DIN 3852	M12 × 1.5; 12 deep	M12 × 1.5; 12 deep	350	X
M_H Measuring port, high pressure	DIN 3852	-	M12 × 1.5; 12 deep	350	X

1) The countersink may be deeper than specified in the standard.
Ports designed for straight stud ends according to EN ISO 9974-2 type E.

2) Depending on the application, momentary pressure peaks can occur. Keep this in mind when selecting measuring devices and fittings.

3) X = Plugged (in normal operation)

Filtration in the boost pump suction line

Version S

Filter version	Suction filter
Recommendation	With contamination indicator, with cold start valve
Recommended flow resistance at filter element	
At $v = 30 \text{ mm}^2/\text{s}$, $n = n_{\text{max}}$	$\Delta p = 0.1 \text{ bar}$
At $v = 1000 \text{ mm}^2/\text{s}$, $n = n_{\text{max}}$	$\Delta p = 0.3 \text{ bar}$
Pressure at suction port S	
Continuous $p_{S \text{ min}}$ ($v \leq 30 \text{ mm}^2/\text{s}$)	$\geq 0.8 \text{ bar abs.}$
Short-term, at a cold start ($t < 3 \text{ min}$)	$\geq 0.5 \text{ bar abs.}$
Maximum pressure $p_{S \text{ max}}$	$\leq 5 \text{ bar abs.}$

Use of version S is preferred.

The suction filter is not included in the scope of delivery.

▼ Circuit diagram sizes 28 and 45

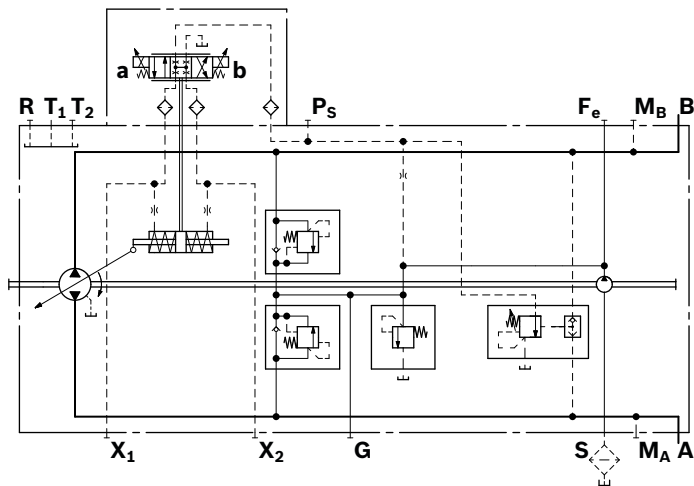

▼ Circuit diagram size 63

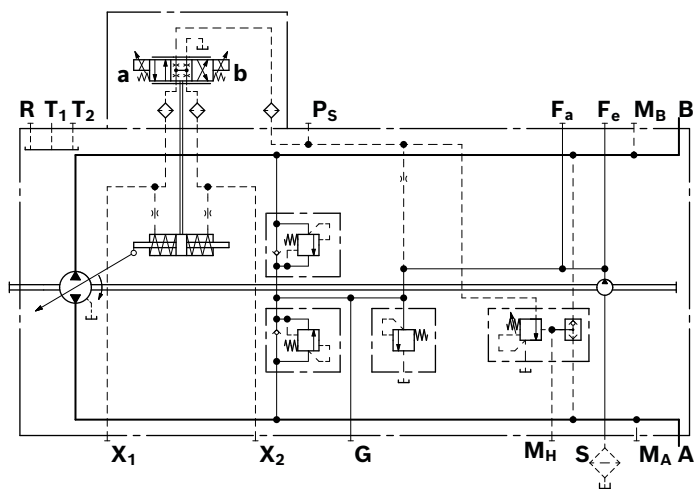

Filtration in the boost pump pressure line

Version D

Ports for external boost circuit filtration

Ports		
Boost pressure inlet	NG 28, 45	Port G (F _a)
	NG 63	Port F_a
Boost pressure outlet		Port F_e
Filter version	Boost pressure filter	
Recommendation	With contamination indicator, with cold start valve	
Filter arrangement	Separate in the pressure line (inline filter)	

The boost pressure filter is not included in the scope of delivery.

Notice

- ▶ In connection with a DA control valve, no pressure filtration is possible with NG28 and 45.
- ▶ For NG28 and 45, port **G** serves as "boost pressure port inlet".
- ▶ Filters with bypass are **not recommended**, (exception DG, see below). Please contact us for applications with a bypass.
- ▶ On versions with DG control (with pilot pressure not from a boost circuit), a filter must be used that fulfills the requirements with regard to filtration of the hydraulic fluid (see page 6).
- ▶ The pressure drop at the filter is viscosity- and contamination-dependent. Note the maximum permissible pressure of the boost pump in combination with the set feed pressure.

▼ Circuit diagram sizes 28 and 45

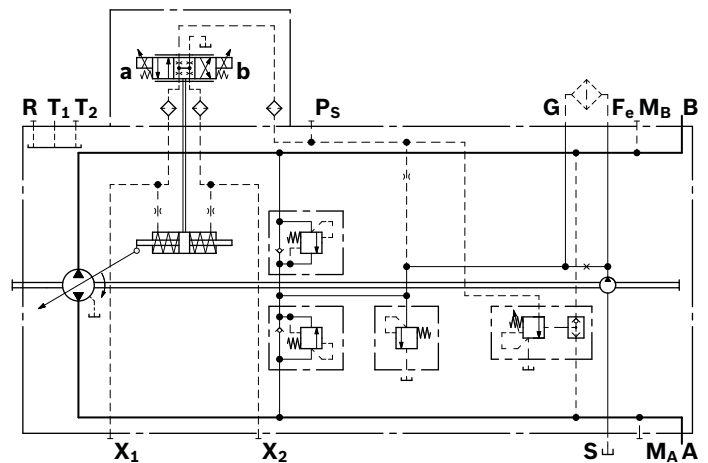

▼ **Circuit diagram size 63**

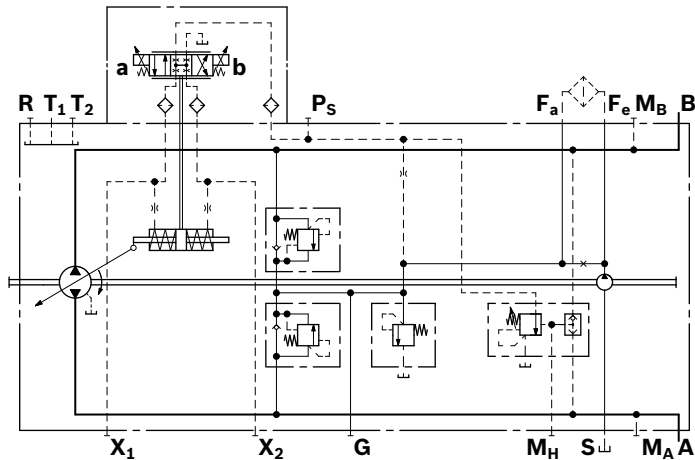

Notice

Bosch Rexroth has a comprehensive filter range on offer. An inline filter, e.g. the 110 LEN (see data sheet 51448), is suitable for charge pressure filtration. Further information can also be found at www.boschrexroth.com/filter.

External boost pressure supply

Version E

This variation should be used in versions without integrated boost pump (**N** and/or **K**).
With sizes 28, 45 and 63, port **S** is plugged.

▼ **Boost pressure supply**

Size	Port
18	S
28, 45 (without DA control valve)	G
28, 45 (with DA control valve)	Fe
63	Fa

The filter should be installed separately on port **Fa**, **Fe**, **G** or **S** before the boost pressure supply.

To ensure the functional reliability, maintain the required cleanliness level for the boost pressure fluid fed in at port **Fa**, **Fe**, **G** or **S** (see page 6).

▼ **Circuit diagram sizes 28 and 45**
Boost pressure supply at port G

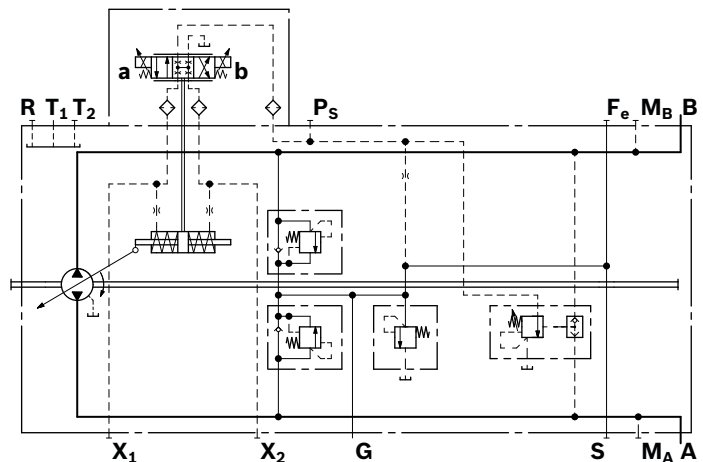

▼ **Circuit diagram size 63**
Boost pressure supply at port Fa

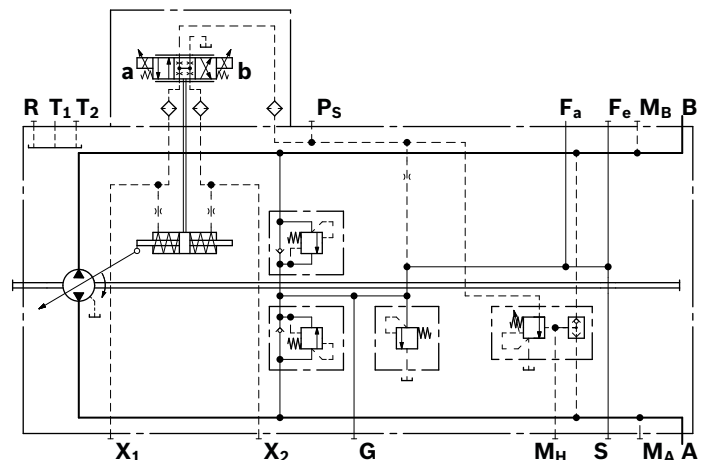

Connector for solenoids

DEUTSCH DT04-2P-EP04

- ▶ **P:** Molded, 2-pin, without bidirectional suppressor diode (standard).
- ▶ **Q:** Molded, 2-pin, with bidirectional suppressor diode (only for switching solenoids on control module EZ, DA and ED)

The following type of protection ensues with the installed mating connector:

- ▶ IP67 (DIN/EN 60529) and
- ▶ IP69K (DIN 40050-9)

The protection circuit with bidirectional suppressor diode is needed to limit overvoltages. Overvoltages are caused by switching off the current with switches, relay contacts or by disconnecting the mating connector while voltage is applied.

▼ Switching symbol

without bidirectional suppressor diode

with bidirectional suppressor diode

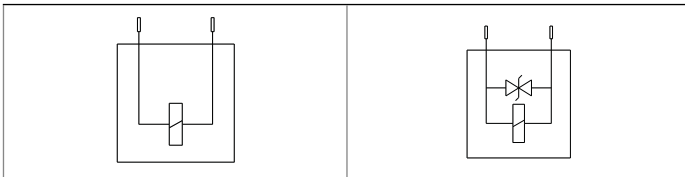

▼ Mating connector DEUTSCH DT06-2S-EP04

Consisting of	DT designation
1 housing	DT06-2S-EP04
1 wedge	W2S
2 sockets	0462-201-16141

The mating connector is not included in the scope of delivery. This can be supplied by Bosch Rexroth on request (material number R902601804).

Notice

- ▶ If necessary, you can change the position of the connector by turning the solenoid body.
- ▶ The procedure is defined in the instruction manual.

Rotary inch valve

The rotary inch valve allows for any reduction of pilot pressure, independently of drive speed, through mechanical actuation of the control lever. The control lever is equipped with an internal rotational limiter $\pm 90^\circ$ (drawing item **1** and **2**).

The valve is arranged separately from the pump and is connected to the pump by a hydraulic control line via port **P_S** (maximum line length: approx. 2 m).

The rotary inch valve must be ordered separately.

Material number	Direction of actuation of the position control lever	Throttle cross-section \varnothing
R902048734	Clockwise	4.6
R902048735	Counter-clockwise	4.6
R902070172	Clockwise	2.7
R902066994	Counter-clockwise	2.7

Notice

The rotary inch valve can be used regardless of the control module. If necessary, the position of the control lever can be changed.

▼ Circuit diagram

Hydraulic control, speed related
DA with separately attached rotary inch valve

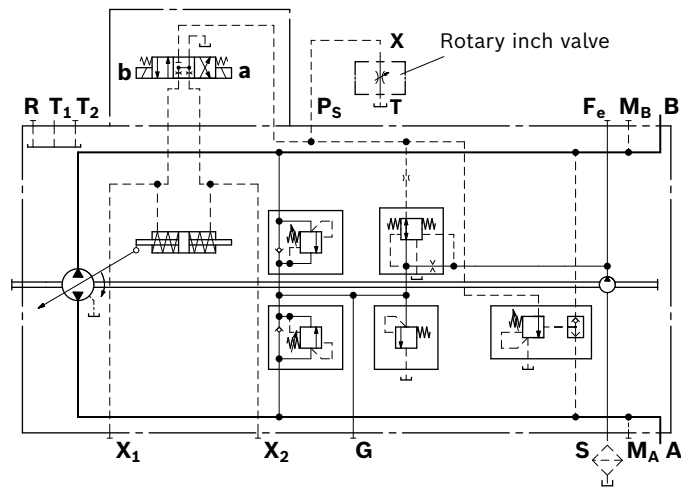

Dimensions

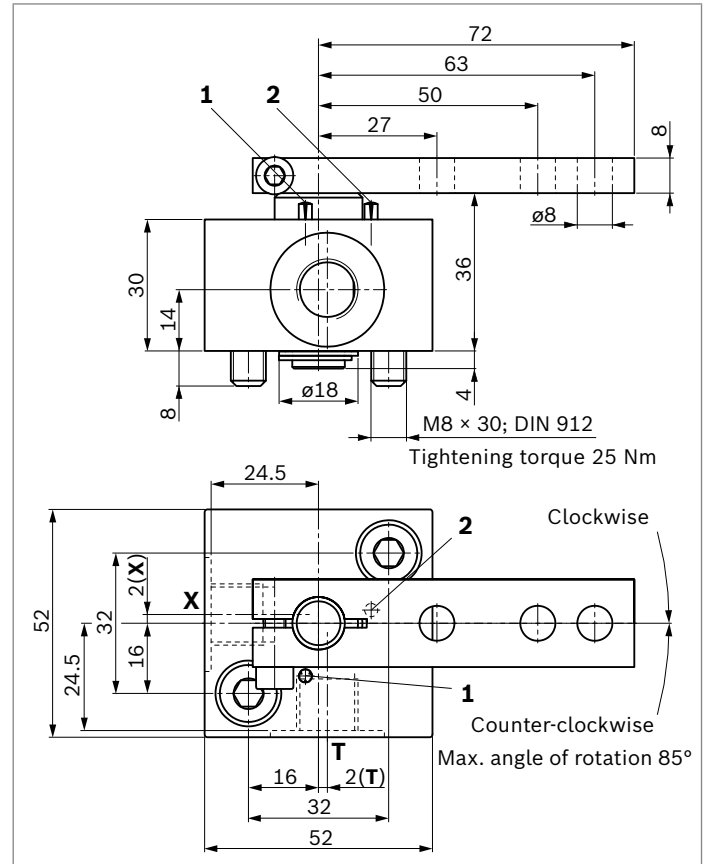

Notice

To prevent damage to the rotary inch valve, a positive mechanical stop of $\pm 85^\circ$ must be provided for the control lever on the customer side.

Ports	Standard ¹⁾	Size	p_{\max} [bar] ²⁾	State ³⁾	
X	Pilot pressure port	DIN 3852	M14 × 1.5; 12 deep	40	O
T	Drain port	DIN 3852	M14 × 1.5; 12 deep	3	O

- 1) The countersink may be deeper than specified in the standard. Ports designed for straight stud ends according to EN ISO 9974-2 type E.
- 2) Depending on the application, momentary pressure peaks can occur. Keep this in mind when selecting measuring devices and fittings.
- 3) O = Must be connected (plugged on delivery)

Installation dimensions for coupling assembly

To ensure that rotating components (coupling hub) and fixed components (housing, retaining ring) do not come into contact with each other, the installation conditions described here must be observed. This depends on the pump size and the splined shaft.

SAE splined shaft (spline according to ANSI B92.1a)

Splined shaft **S** and/or **T**

The outer diameter of the coupling hub must be smaller than the inner diameter of the retaining ring (dimension d_2) in the area near the drive shaft collar (dimension $x_2 - x_3$).

Observe diameter of relief on sizes 18, 28 and 45.

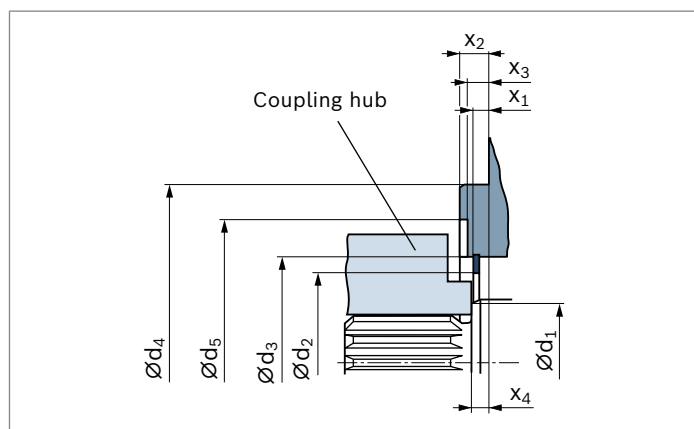

NG	$\varnothing d_1$	$\varnothing d_{2 \text{ min}}$	$\varnothing d_3$	$\varnothing d_4$	$\varnothing d_5$	x_1	x_2	x_3	x_4
18	28.5	36.1	49±0.1	101.6 ⁰ _{-0,054}	65	5.9 ^{+0.2}	9.5 ^{-0.5}	7	8 ^{+0.9} _{-0.6}
28	33.5	43.4	55±0.1	101.6 ⁰ _{-0,054}	72	3.9 ^{+0.2}	9.5 ^{-0.5}	7	8 ^{+0.9} _{-0.6}
45	38.5	51.4	63±0.1	101.6 ⁰ _{-0,054}	80	4.3 ^{+0.2}	9.5 ^{-0.5}	7	8 ^{+0.9} _{-0.6}
63	38.5	54.4	68±0.1	127.0 ⁰ _{-0,063}	-	7.0 ^{+0.2}	12.7 ^{-0.5}	-	8 ^{+0.9} _{-0.6}

Installation instructions

General

The axial piston unit must be filled with hydraulic fluid and air bled during commissioning and operation. This must also be observed following a longer standstill as the axial piston unit may empty via the hydraulic lines.

Particularly in the installation position "drive shaft upwards", filling and air bleeding must be carried out completely as there is, for example, a danger of dry running.

The leakage in the housing area must be directed to the reservoir via the highest drain port (**T₁**, **T₂**).

For combination pumps, the leakage must be drained off at each single pump.

If a shared drain line is used for several units, make sure that the respective case pressure in each unit is not exceeded. The shared drain line must be dimensioned to ensure that the maximum permissible case pressure of all connected units is not exceeded in any operating condition, particularly at cold start. If this is not possible, separate drain lines must be laid, if necessary.

To achieve favorable noise values, decouple all connecting lines using elastic elements and avoid above-reservoir installation.

Under all operating conditions, the suction line and drain line must flow into the reservoir below the minimum fluid level. The permissible suction height h_s results from the total pressure loss; it must not, however, be higher than $h_{s \max} = 800 \text{ mm}$.

The suction pressure at port **S** must also not fall below the minimum value of 0.8 bar absolut during operation (cold start 0.5 bar absolute).

Installation position

See the following examples 1 to 12.

Further installation positions are available upon request.
Recommended installation position: 1 and 2.

Notice

- ▶ If filling the stroking chambers via **X₁** to **X₂** is not possible in the final installation position, then this must take place before installation, e.g. in installation position 2.
- ▶ To prevent unexpected actuation and damage, the stroking chambers must be air bled via the ports **X₁**, **X₂** depending on the installation position.
- ▶ In certain installation positions, an influence on the adjustment or control can be expected. Gravity, dead weight and case pressure can cause minor characteristic shifts and changes in response time.

Below-reservoir installation (standard)

Below-reservoir installation means that the axial piston unit is installed outside of the reservoir below the minimum fluid level.

Installation position	Air bleed the housing	Air bleed the stroking chamber	Filling
1	R	X₁ + X₂	S + T₁ + X₁ + X₂
2	-	-	S + T₂ + X₁ + X₂

Diagram 1: Below-reservoir installation with drive shaft upwards. The pump is oriented vertically with the drive shaft at the top. Port R is at the top left, X1 and X2 are at the top center, T1 is at the top right, T2 is at the bottom left, and S is at the bottom right. A reservoir is shown above the pump with a fluid level indicated by a dashed line. The suction line (S) and drain line (T1) are connected to the reservoir. The minimum suction height is labeled $h_{t \min}$ and the minimum drain height is labeled h_{\min} .

Diagram 2: Below-reservoir installation with drive shaft downwards. The pump is oriented vertically with the drive shaft at the bottom. Port S is at the top left, T2 is at the top right, and X1 and X2 are at the bottom center. A reservoir is shown above the pump with a fluid level indicated by a dashed line. The suction line (S) and drain line (T2) are connected to the reservoir. The minimum suction height is labeled $h_{t \min}$ and the minimum drain height is labeled h_{\min} .

Installation position	Air bleed the housing	Air bleed the stroking chamber	Filling
3	-	$X_1 + X_2$	$S + T_2 + X_1 + X_2$

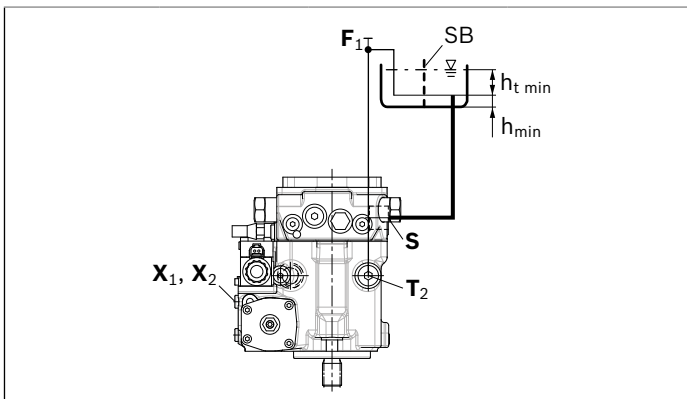

4	R	-	$S + T_2 + X_1 + X_2$
----------	----------	---	-----------------------

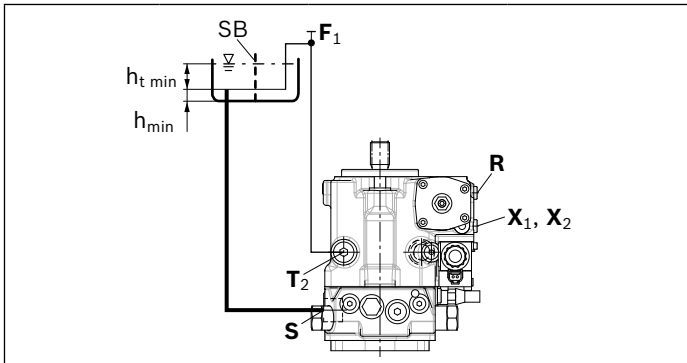

5	-	X_1	$S + T_1 + X_1 + X_2$
----------	---	-------	-----------------------

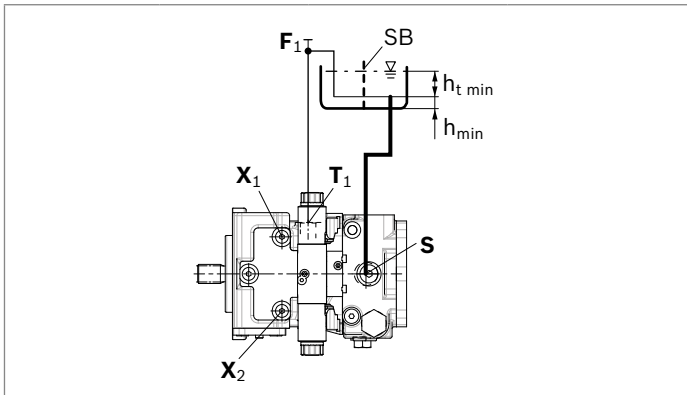

6	-	X_2	$S + T_2 + X_1 + X_2$
----------	---	-------	-----------------------

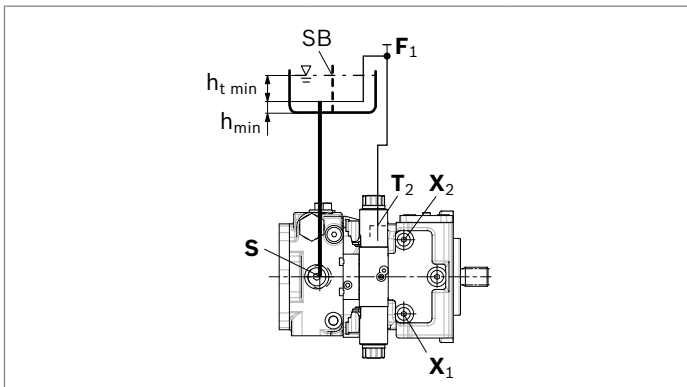

Above-reservoir installation

Above-reservoir installation means that the axial piston unit is installed above the minimum fluid level of the reservoir.

Observe the maximum permissible suction height

$h_{S \max} = 800 \text{ mm}$.

Recommendation for installation position 10

(drive shaft upward): A check valve in the drain line (cracking pressure 0.5 bar) can prevent the housing area from draining.

Installation position	Air bleed the housing	Air bleed the stroking chamber	Filling
7	$F_2 + R$	$X_1 + X_2$	$F_2 + F_1 + X_1 + X_2$

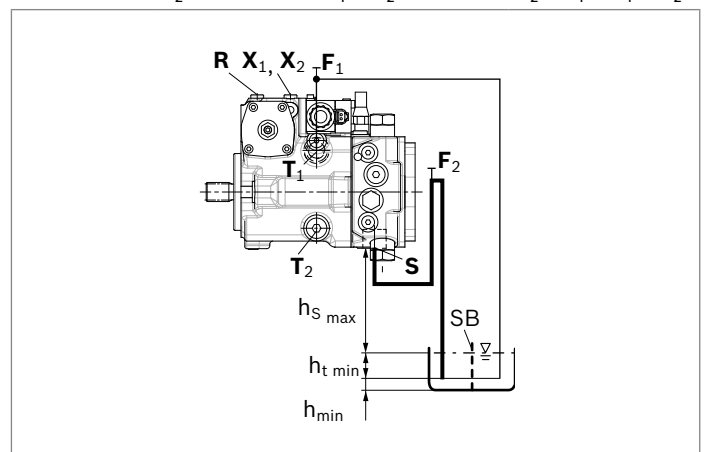

8	$F_2 (S) + F_1 (T_2) -$		$F_2 (S) + F_1 (T_2) + X_1 + X_2$
----------	-------------------------	--	-----------------------------------

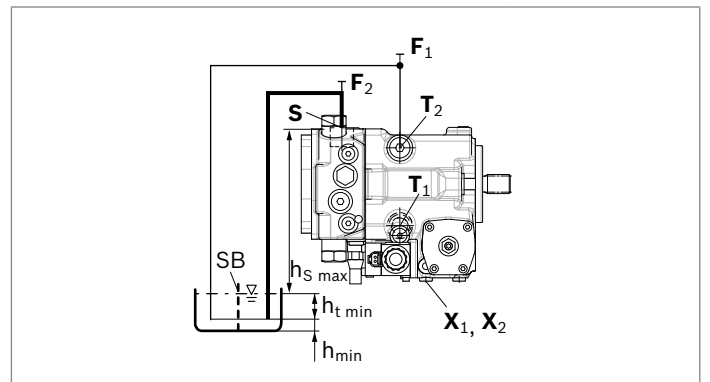

9	$F_2 (S) + F_1 (T_2)$	$X_1 + X_2$	$F_2 (S) + F_1 (T_2) + X_1 + X_2$
----------	-----------------------	-------------	-----------------------------------

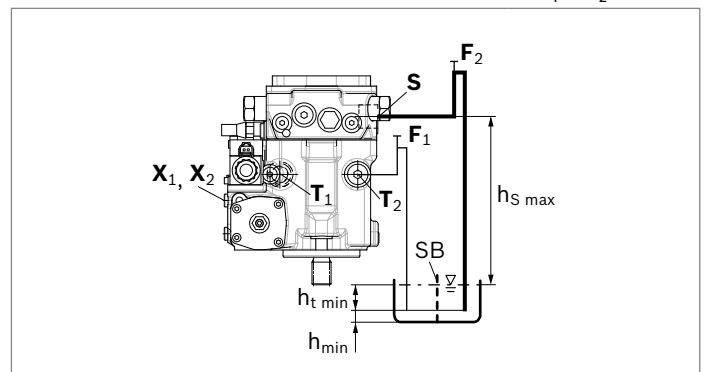

Installation position	Air bleed the housing	Air bleed the stroking chamber	Filling
10	$F_2 + F_1$ (R)	-	$F_2 + F_1 + X_1 + X_2$

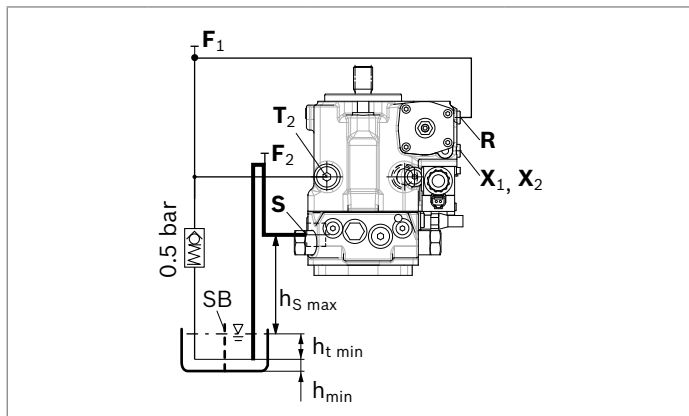

11	F_2 (S) + F_1 (T ₁)	X_1	F_2 (S) + F_1 (T ₁) + $X_1 + X_2$
-----------	-------------------------------------	-------	---

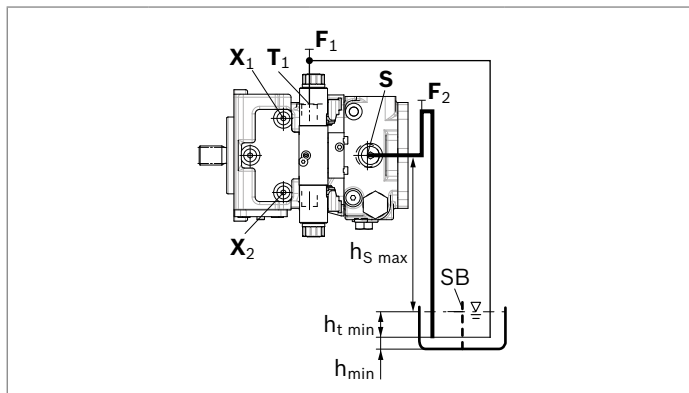

12	F_2 (S) + F_1 (T ₂)	X_2	F_2 (S) + F_1 (T ₂) + $X_1 + X_2$
-----------	-------------------------------------	-------	---

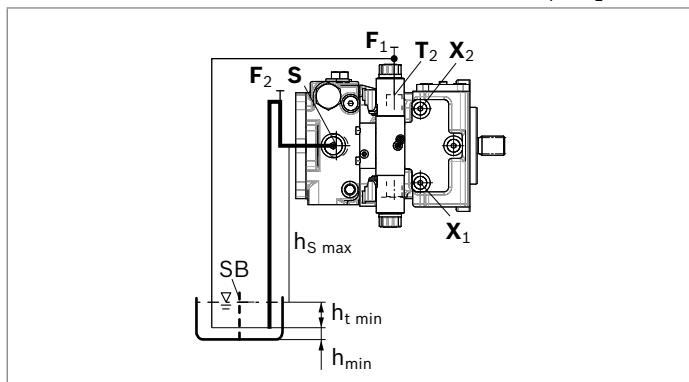

Key	
F_1, F_2	Filling/air bleeding
R	Air bleed port
S	Suction port
T_1, T_2	Drain port
X_1, X_2	Control pressure port
SB	Baffle (baffle plate)
$h_{t \min}$	Minimum required immersion depth (200 mm)
h_{\min}	Minimum required distance to reservoir bottom (100 mm)
$h_{s \max}$	Maximum permissible suction height (800 mm)

Notice

Ports F_1 and F_2 are part of the external piping and must be provided by the customer to make filling and air bleeding easier.

Project planning notes

- ▶ The pump is designed to be used in a closed circuit.
- ▶ The project planning, installation and commissioning of the axial piston unit require the involvement of qualified skilled personnel.
- ▶ Before using the axial piston unit, please read the corresponding instruction manual completely and thoroughly. If necessary, this can be requested from Bosch Rexroth.
- ▶ Before finalizing your design, please request a binding installation drawing.
- ▶ The specified data and notes contained herein must be observed.
- ▶ Depending on the operating conditions of the axial piston unit (working pressure, fluid temperature), the characteristic curve may shift.
- ▶ Preservation: Our axial piston units are supplied as standard with preservative protection for a maximum of 12 months. If longer preservation is required (maximum 24 months), please specify this in plain text when placing your order. The preservation periods apply under optimal storage conditions, details of which can be found in data sheet 90312 or in the instruction manual.
- ▶ Not all versions of the product are approved for use in a safety function according to ISO 13849. Please consult the responsible contact person at Bosch Rexroth if you require reliability parameters (e.g. $MTTF_D$) for functional safety.
- ▶ Depending on the type of control used, electromagnetic effects can be produced when using solenoids. Applying a direct voltage signal (DC) to solenoids does not create electromagnetic interference (EMI) nor is the solenoid affected by EMI. Electromagnetic interference (EMI) potential exists when operating and controlling a solenoid with a modulated direct voltage signal (e.g. PWM signal). Appropriate testing and measures should be taken by the machine manufacturer to ensure other components or operators (e.g. with pacemaker) are not affected by this potential.
- ▶ The pressure cut-off is not a safeguard against pressure overload. Be sure to add a pressure relief valve to the hydraulic system.
- ▶ With dynamic power flow (switch of pumps to operation as a motor) a maximum of 95% $V_{g \max}$ is permissible. We recommend configuring the software accordingly.
- ▶ For drives that are operated for a long period with constant rotational speed, the natural frequency of the hydraulic system can be stimulated by the stimulator frequency of the pump (rotational speed frequency $\times 9$). This can be prevented with suitably designed hydraulic lines.
- ▶ Please note the details regarding the tightening torques of port threads and other threaded joints in the instruction manual.
- ▶ Working ports:
 - The ports and fastening threads are designed for the specified maximum pressure. The machine or system manufacturer must ensure the connecting elements and lines correspond to the specified application conditions (pressure, flow, hydraulic fluid, temperature) with the necessary safety factors.
 - The working ports and function ports are only intended to accommodate hydraulic lines.

Safety instructions

- ▶ During and shortly after operation, there is a risk of getting burnt on the axial piston unit and especially on the solenoids. Take the appropriate safety measures (e.g. by wearing protective clothing).
- ▶ Moving parts in control equipment (e.g. valve spools) can, under certain circumstances, get stuck in position as a result of contamination (e.g. contaminated hydraulic fluid, abrasion, or residual dirt from components). As a result, the hydraulic fluid flow and the build-up of torque in the axial piston unit can no longer respond correctly to the operator's specifications. Even the use of various filter elements (external or internal flow filtration) will not rule out a fault but merely reduce the risk. The machine/system manufacturer must test whether remedial measures are needed on the machine for the application concerned in order to bring the driven consumer into a safe position (e.g. safe stop) and ensure any measures are properly implemented.
- ▶ Moving parts in high-pressure relief valves may in certain circumstances become stuck in an undefined position due to contamination (e.g. impure hydraulic fluid). This can result in restriction or loss of load-holding functions in lifting winches.
The machine/system manufacturer must check whether additional measures are required on the machine for the relevant application in order to keep the load in a safe position and ensure they are properly implemented.

Bosch Rexroth AG

Glockeraustraße 4
89275 Elchingen
Germany
Phone +49 7308 82-0
info.ma@boschrexroth.de
www.boschrexroth.com

© Bosch Rexroth AG 2019. All rights reserved, also regarding any disposal, exploitation, reproduction, editing, distribution, as well as in the event of applications for industrial property rights. The data specified within only serves to describe the product. No statements concerning a certain condition or suitability for a certain application can be derived from our information. The information given does not release the user from the obligation of own judgment and verification. It must be remembered that our products are subject to a natural process of wear and aging.