

EAT•N

Hydraulics

420 Mobile Piston Pump

Technical Catalog Manual

ADU041

ADU049

ADU062



Introduction

420 Series mobile pumps are open circuit, axial piston designs. A variety of controls provides the ability to match the pumps to each application. Efficiency of the pump controls allows down-sizing of system cooling needs, allowing a smaller and less expensive design to be used. Alternatively, cooling capacity could be kept the same and the flow capability of the system increased, thus improving performance and customer satisfaction.

A strong proven rotating group allows the pumps to handle pressures to 280 bar (4000 psi) continuous and 320 bar (4600 psi) intermittent – with less maintenance cost. High load bearings and a stiff drive shaft help provide a pump B10 bearing life of 3320 hours at rated mobile conditions, reducing operating costs and extending operating life.

420 Series pumps feature a saddle-type swashplate with steel-backed polymer bearings. The swashplate features a pressure lubrication passage to reduce wear and further support internal loads. The stiff swashplate reduces deflection and allows even loading of the bearings, improving life. A single control piston reduces forces acting on the swashplate, resulting in reduced package size, which allows pump installation into tighter locations.

420 Series pumps operate at a level of quietness that exceeds the requirements of today's demanding work conditions. Another pump feature – a bimetal timing plate – improves pump filling characteristics which, in turn, reduces fluid-borne noise and extends pump life.

Mounting flanges are offered in SAE and ISO configurations, and ports are offered in SAE and ISO tube and flange versions. This provides a wide variety of installation opportunities for global machine design.

Side- or end-ported models are available to facilitate plumbing and help fit the pump to your machine space needs. Multiple drain ports allow many mounting orientations, reducing installed costs.



420 Series mobile pump

Typical Applications

- Loader backhoes
- Vibratory cable plows
- Mining machinery
- Dump truck lifts
- Agriculture tractors
- Chemical applicator trucks
- Railroad equipment
- Container handling, all-terrain, and truck cranes
- Vibratory cable plows
- Mining machinery and tunnel boring equipment
- Utility boom, off-road dump, and refuse trucks
- Material handling trucks and rough terrain fork lifts
- Concrete and asphalt pavers
- Feller/bunchers, forwarders, and log loaders
- Crawler dozers
- Articulate haulers
- Mini-excavators

Features and Benefits

- Long pump life
- Quiet pump operation
- Low installed and operating costs
- Reduced maintenance
- Flexibility in machine design
- Compact size saves space
- Design promotes leak-free system

Table of Contents

Model Codes	4
Specifications and Performance	6
Control Options	7
Performance	
ADU041 (Being Readied for Production)	
ADU049 (Being Readied for Production)	
ADU062	9
Dimensions	
Pump Installation – Rear-Ported	12
Pump Installation – Side-Ported	16
Pump Installation – Thru-Drive SAE A Option	20
Pump Installation – Thru-Drive SAE B Option	25
Pump Installation – Dual Shaft Seal	29
Pump Installation – External Manual Stroke Adjustment	30
Pump Control Installation	31
Shaft Installation	33
Operating Requirements and Recommendations	35
Installation and Start-up	36

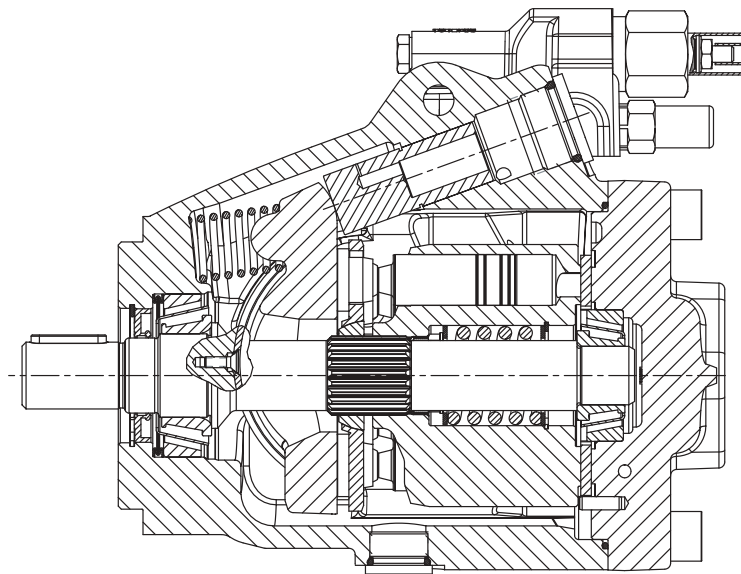

Model Codes

420 Mobile Piston Pump

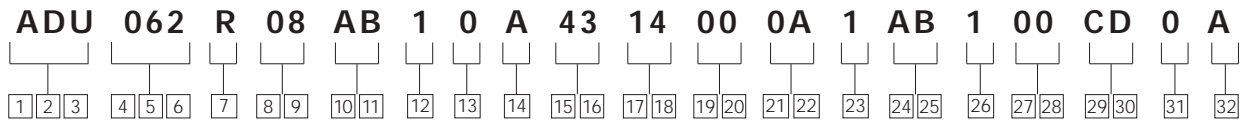

1 2 3 Pump Series

ADU – 420 Series Open Circuit Piston Pump

4 5 6 Pump Displacement

041 – 41.0 cm³/r [2.50 in³/r]
049 – 49.2 cm³/r [3.00 in³/r]
062 – 62.3 cm³/r [3.80 in³/r]

7 Input Shaft Rotation

R – Right Hand (Clockwise)
 Right Side Suction Port;
 Left Side Pressure Port
L – Left Hand
 (Counter-clockwise)
 Left Side Suction Port;
 Right Side Pressure Port

8 9 Front Mount and Shaft

01 – 2 Bolt B (SAE J744-101-2) with 22.2mm (0.88in.) Diameter Straight Key Shaft (SAE J744-22-1) (Key Included)
02 – 2 Bolt B (SAE J744-101-2) with 25.4mm (1.00in.) Diameter Straight Key Shaft (SAE J744-25-1) (Key Included)
04 – 2 Bolt B (SAE J744-101-2) with 25.4mm (1.00in.) Diameter Tapered Key Shaft (SAE J744-25-3) (Key Included), .750-16 UNF-2B Thread, Shaft Extension 69.8mm (2.75in.)
05 – 2 Bolt B (SAE J744-101-2) with 13 Tooth 16/32 Spline (ANSI B92. 1-1996 MOD.), Shaft Extension 41.1mm (1.62in.)

08 – 2 Bolt B (SAE J744-101-2) with 15 Tooth 16/32 Spline (ANSI B92. 1-1996 MOD.), Shaft Extension 46mm (1.81in.)

30 – 2 Bolt B (SAE J744-101-2) with .125:1 25.4mm (1.00in.) Diameter Tapered Shaft, 6.38mm (.251in.) Wide x 19.8mm (0.78in.) Long Keyway, .375-24 UNF-2B Thread; 35.1mm (1.38in.) Shaft Extension

31 – 2 Bolt B (SAE J744-101-2) with 25.4 [1.00] Diameter Straight Key Shaft w/Internal .375-24 UNF-2B Thread

10 11 Main Ports Size & Location

AA – Rear Ports; Suction - 2.00 SAE J518 4-Bolt Split Flange Port Standard Pressure Series (Code 61); Pressure - 1.00 SAE J518 4-Bolt Split Flange Port Standard Pressure Series (Code 61)

AB – Side Ports, Suction - 2.00 SAE J518 4-Bolt Split Flange Port Standard Pressure Series (Code 61); Pressure - 1.00 SAE J518 4-Bolt Split Flange Port Standard Pressure Series (Code 61)

AC – Rear Ports, Suction - 2.00 4-Bolt Split Flange Port Standard Pressure Series (Code 61) with M12 x 1.75 Thread; Pressure - 1.00 4-Bolt Split Flange Port Standard Pressure Series (Code 61) with M10 x 1.5 Thread

AD – Side Ports, Suction - 2.00 4-Bolt Split Flange Port

Standard Pressure Series (Code 61) with M12 x 1.75 Thread; Pressure - 1.00 4-Bolt Split Flange Port Standard Pressure Series (Code 61) with M10 x 1.5 Thread

AE – Rear Ports, Suction - 1.875-12 UN-2B SAE O-Ring Port; Pressure - 1.3125-12 UN-2B SAE O-Ring Port (49.2mm [3.00in.] and 41.0mm [2.50in.] Displacements ADU041 and ADU049 Only)

AF – Side Ports, Suction - 1.875-12 UN-2B SAE O-Ring Port; Pressure - 1.3125-12 UN-2B SAE O-Ring Port (49.2mm [3.00in.] and 41.0mm [2.50in.] Displacements ADU041 and ADU049 Only)

AG – Rear Ports, Suction - M48 x 2 Metric O-Ring Port; Pressure - M33 x 2 Metric O-Ring Port (49.2mm [3.00in.] and 41.0mm [2.50in.] Displacements ADU041 and ADU049 Only)

AH – Side Ports, Suction - M48 x 2 Metric O-Ring Port; Pressure - M33 x 2 Metric O-Ring Port (49.2 [3.00] and 41.0 [2.50] Displacements ADU041 and ADU049 Only)

AK – Rear Ports, Suction - 2.00 SAE J518 4-Bolt Split Flange Port Standard Pressure Series (Code 61); Pressure - 1.3125-12 UN-2B SAE O-Ring Port

12 Case Drain Ports

1 – .875-14 UNF-2B O-Ring Port - Top
2 – .875-14 UNF-2B O-Ring Port - Bottom
3 – M22 x 1.5 O-Ring Port - Top
4 – M22 x 1.5 O-Ring Port - Bottom

13 Diagnostic Pressure Ports

0 – No Diagnostic Pressure Ports
1 – .5625-18 UNF-2B SAE O-Ring Ports - Suction and Pressure Ports - Plugged
2 – M14 x 1.5 Metric O-Ring Ports - Suction and Pressure Ports - Plugged

14 Controller Type

A – Pressure Flow Compensator With .4375-20 SAE O-Ring Load Sense Port
B – Pressure Flow Compensator With M14 x 1.5 Metric O-Ring Load Sense Port
C – Pressure Compensator Only

Model Codes

420 Mobile Piston Pump

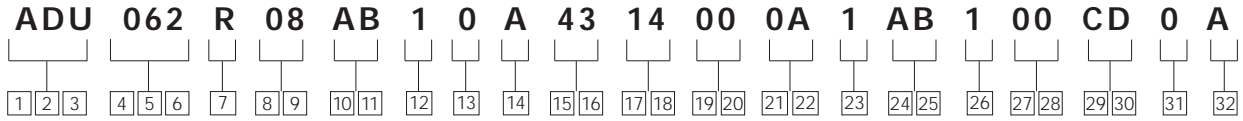

[15][16] Pressure Compensator Setting (Tolerance on Setting)

- 28** – 206.8-213.7 bar [3000-3100 lbf/in²]
- 35** – 241.3-248.2 bar [3500-3600 lbf/in²]
- 43** – 275.8-282.7 bar [4000-4100 lbf/in²]

[17][18] Flow Compensator Setting (Tolerance on Setting)

- 00** – No Flow Compensator Setting
- 10** – 9.65-12.41 bar [140-180 lbf/in²]
- 14** – 12.41-15.17 bar [180-220 lbf/in²]
- 20** – 17.24-19.99 bar [250-290 lbf/in²]
- 24** – 22.75-25.51 bar [330-370 lbf/in²]

[19][20] Secondary Compensator Setting

- 00** – No Secondary Compensator

[21][22] Control Special Features
00 – No Control Special Features
0A – Bleed Down Orifice

[23] Maximum Displacement Option

- 1** – Standard Displacement (As Given In Code Title)
- 2** – External Manual Stroke Adjustment

[24][25] Auxiliary (Rear) Mount & Output Shaft

- 00** – No Auxiliary Mounting Features
- AA** – Dual SAE J744 Flange 82-2 (2 Bolt A); Accepts 9T 16/32 Spline with 31.7 [1.25] Shaft Extension (No Coupler Required)
- AB** – Dual SAE J744 Flange 82-2 (2 Bolt A); Accepts 11T 16/32 Spline with 31.7 [1.25] Shaft Extension (Coupler Included)
- AC** – Dual SAE J744 Flange 101-2 (2 Bolt B); Accepts 13T 16/32 Spline with 41.2 [1.62] Extension (Coupler Included)

[26] Shaft Seal

- 0** – No Shaft Seal
- 1** – Standard Polyacrylate Shaft Seal
- 2** – Fluorocarbon Rubber Shaft Seal
- 3** – Double, Two-Way Shaft Seal, Fluorocarbon With VHO Filter

[27][28] Pump Special Features

- 00** – No Special Features
- AA** – Auxiliary Mounting Cover Plate
- AB** – Swash Position Sensor
- AC** – Shaft Speed Sensor

[29][30] Paint

- 00** – No Paint
- CD** – Blue Per Spec 209-13CD

[31] Identification/Packaging

- 0** – Standard Eaton Identification Box Packaging

[32] Design Level

- A** – First Design

Specifications and Performance

DISPLACEMENT

	cc/rev (cu.in./rev)	Dry Weight kg (lbm)	Dual Seal Weight kg (lbm)
ADU041	41.0 (2.50)	21 (47)	22 (49)
ADU049	49.2 (3.00)	21 (47)	22 (49)
ADU062	62.3 (3.80)	22 (49)	23 (51)

PRESSURE RATINGS

	Continuous bar (psi)	Intermittent bar (psi)	Peak bar (psi)
ADU041	280 (4060)	320 (4600)	350 (5000)
ADU049	280 (4060)	320 (4600)	350 (5000)
ADU062	280 (4060)	320 (4600)	350 (5000)

DYNAMIC RESPONSE

	Response (off stroke) msec	Recovery (on stroke) msec	Load Sense Recovery msec
ADU041	20	75	90
ADU049	20	75	90
ADU062	25	90	115

SPEED RATINGS

Model Series	Maximum Speed Capability (rpm)							
	1bar Inlet (0 psi, flooded)		0.85 bar Inlet (5 in.Hg, vacuum)		3 bar inlet (15 psi, boosted)		Minimum Speed	Maximum Speed at Standby
	Flange Ports	Tube Ports	Flange Ports	Tube Ports	Flange Ports	Tube Ports	(rpm)	(rpm)
ADU041	2650		2450		2950		600	3600
		2650		2450		2950		
ADU049	2650		2450		2850		600	3600
		2650		2450		2850		
ADU062	2600		2400		2800		600	3600
		N/A		N/A		N/A		

POWER AND TORQUE RATINGS

Model Series	Maximum Input Power at Maximum Speed and 40 bar (60 psi) kW (hp)	Standby Power Loss at Maximum Speed and Minimum Pressure kW (hp)	Maximum Torque at 40 bar (60 psi) Nm (lb-ft)
ADU041	50.9 (67.9)	.98 (1.3)	185 (135)
ADU049	61.1 (81.5)	.98 (1.3)	220 (161)
ADU062	75.9 (101.3)	1.1 (1.5)	279 (204)

MASS MOMENT OF INERTIA VALUES

Displacement	Nm-sec ² (lb-in-sec ²)
ADU041	.0033 (.0288)
ADU049	.0033 (.0288)
ADU062	.0096 (.0403)

NOISE LEVEL

Per ISO 3740; Semi-anechoic; Average of 6 microphones
Full Flow @ 49°C (120°F), 210 bar (3000 psi), zero inlet

Model	rpm	dB(A)
ADU062	1800	76

Control Options

Load Sensing and Pressure Compensator Control – Code A or B

The pump will provide power matching of pump output to system load demand, maximizing efficiency and improving load metering characteristics of any directional control valve installed between the pump and the load.

Load sensing ensures that the pump always provides only the amount of flow needed by the load. At the same time, the pump operating pressure adjusts to the actual load pressure plus a pressure differential required for the control action. When the system is not demanding power, the load sense control will operate in an energy-saving stand-by mode.

Typically, the differential pressure is that between the pressure inlet and service port of a proportionally controlled directional valve, or a load sensing directional control valve. See the model code on page 4 for differential pressure settings for load sensing.

If the load pressure exceeds the system pressure setting, the pressure compensator de-strokes the pump. The load sensing line must be as short as possible and can also be used for remote control or unloading of the pump pressure. For remote control purposes, it is recommended that you contact your Eaton Representative for the correct configuration of the control.

Warning: The pressure compensator may be adjusted beyond the rated pressure of the pump. When adjusting the pressure limiter, install a 0-350 bar (0-5000 psi) gage in the outlet gage port and limit the pressure setting to the continuous rated pressure for the pump displacement shown on page 6.

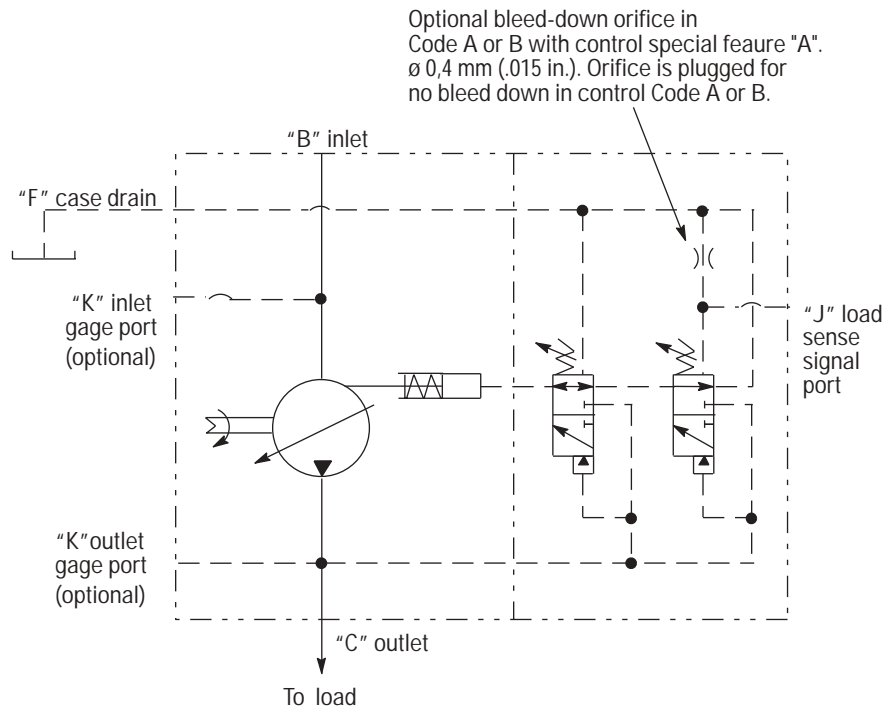

Control Options

Pressure Compensator Control – Code C

The pump will provide a continuously modulated flow to meet changing load demands at a pre-adjusted compensator pressure. At pressures below the compensator setting, the pump will operate at maximum displacement. See model code on page 4 for compensator pressure ranges.

Warning: The pressure compensator may be adjusted beyond the rated pressure of the pump. When adjusting the pressure limiter, install a 0-350 bar (0-5000 psi) gage in the outlet gage port and limit the pressure setting to the continuous rated pressure for the pump displacement shown on page 7.

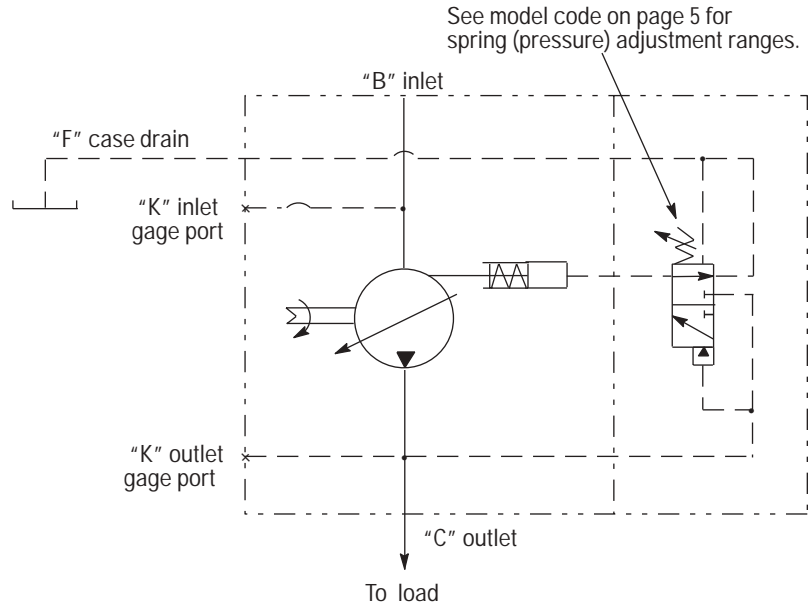

Pressure Cut-off Characteristics of Pressure Compensator Control at 49°C (120°F), static conditions.

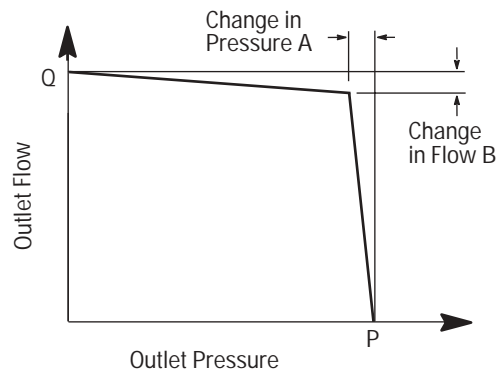

PRESSURE CUT-OFF CHARACTERISTICS OF PRESSURE COMPENSATOR CONTROL @ 49°C (120°F), STATIC CONDITIONS

Model Series	Rated Speed rpm	"Q" Outlet Flow l/min (USgpm)	"P" Outlet Pressure bar (psi)	A bar (psi)	B l/min (USgpm)
ADU041	2650	104 (28)	280 (4060)	6.9 (100)	6.4 (1.7)
ADU049	2650	126 (34)	280 (4060)	6.9 (100)	6.4 (1.7)
ADU062	2600	156 (42)	280 (4060)	6.9 (100)	7.1 (1.9)

Performance 420 Mobile Piston Pump

ADU062

Overall Efficiency Versus
Speed @ 49° C (120° F), Full
Flow, and 1.0 bar (0 psi) Inlet

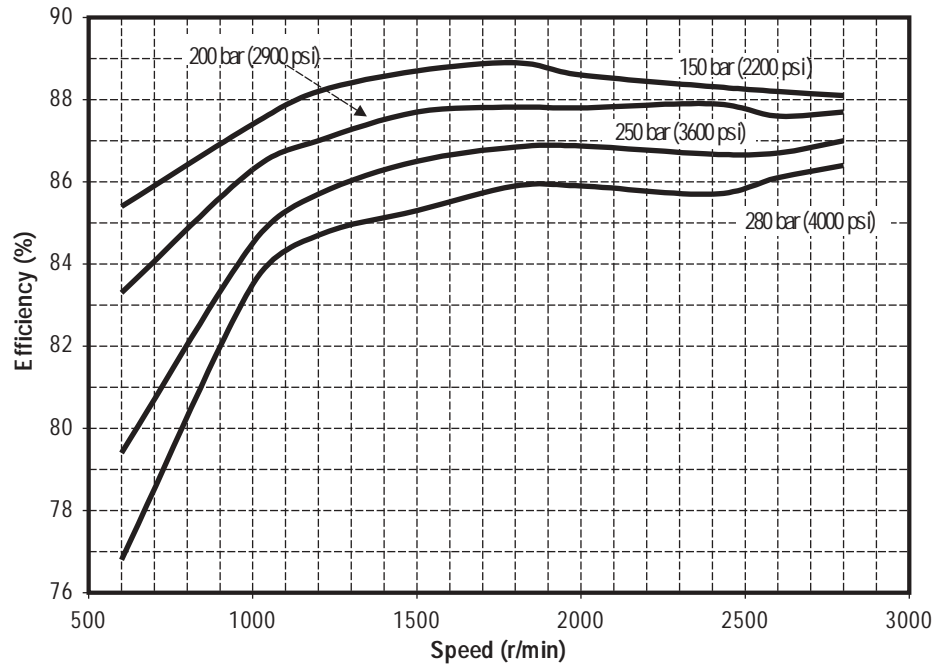

Overall Efficiency Versus
Speed @ 49° C (120° F), Full
Flow, and 1.0 bar (0 psi) Inlet

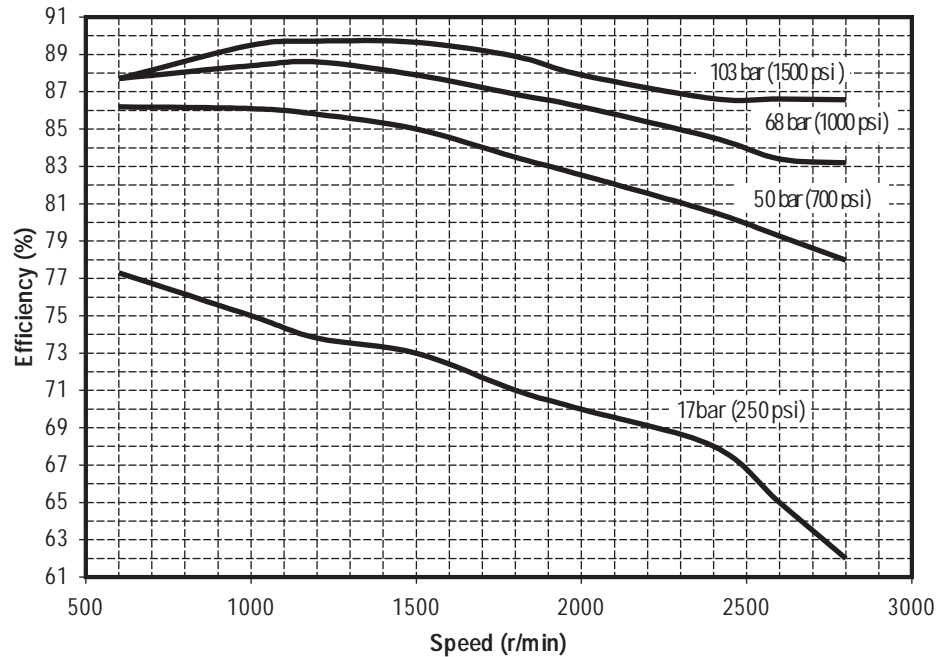

Performance 420 Mobile Piston Pump

ADU062

**Input Torque Versus Speed
@ 49° C (120° F), Full Flow,
and 1.0 bar (0 psi) Inlet**

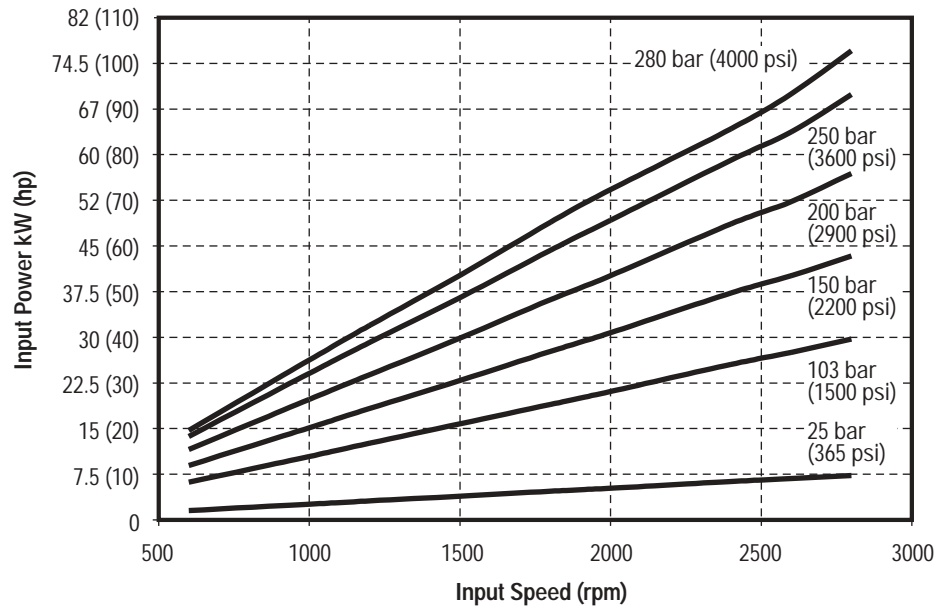

**Input Power Versus Speed @ 49° C (120° F),
Full Flow, and 1.0 bar (0 psi) Inlet**

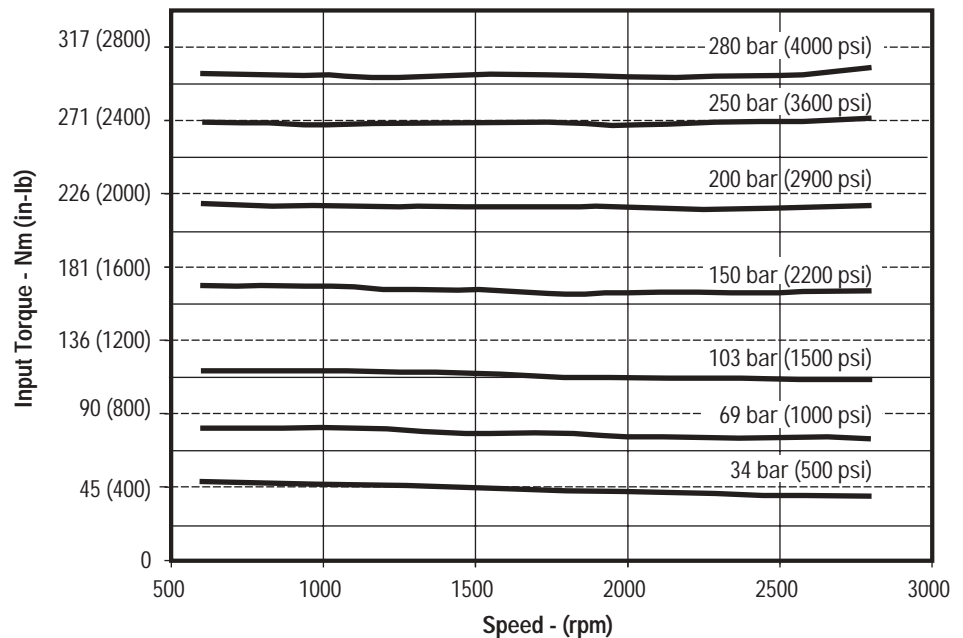

Performance 420 Mobile Piston Pump

ADU062

**Delivery and Case Flow Versus
Speed @ 49° C (120° F)**

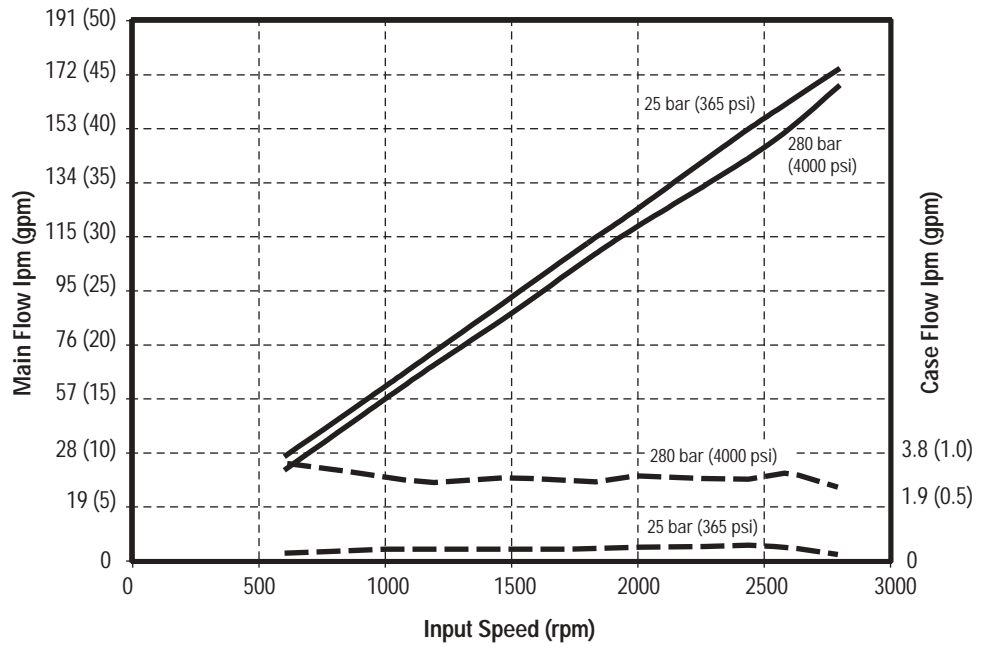

**Input Torque and Case Flow
Stand-by @ 49° C (120° F)**

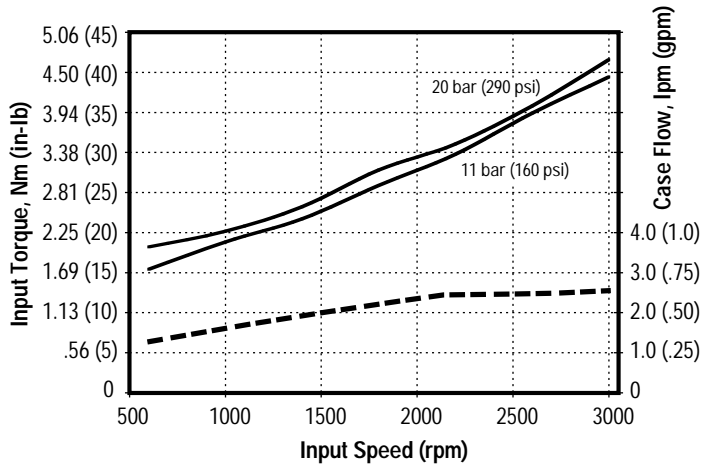

**Input Torque and Case Flow
Cut-off @ 49° C (120° F)**

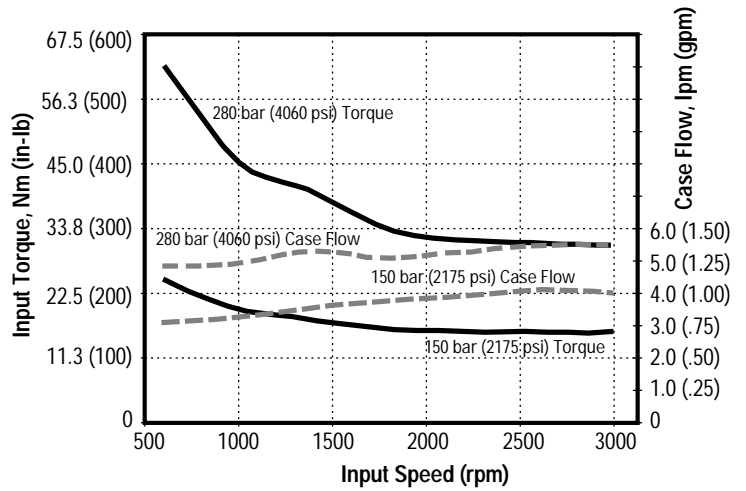

Pump Installation – Rear-Ported

420 Mobile Piston Pump

LH Rotation Flange Ports

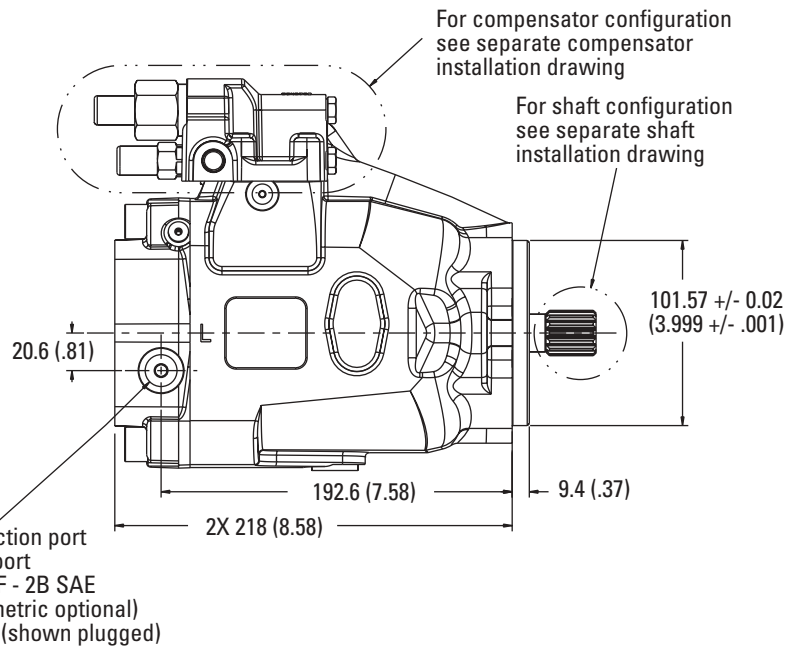
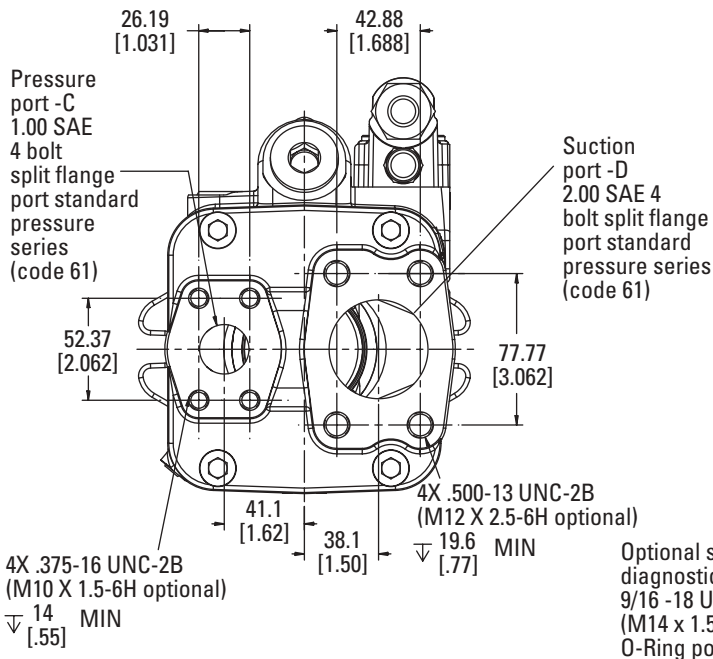
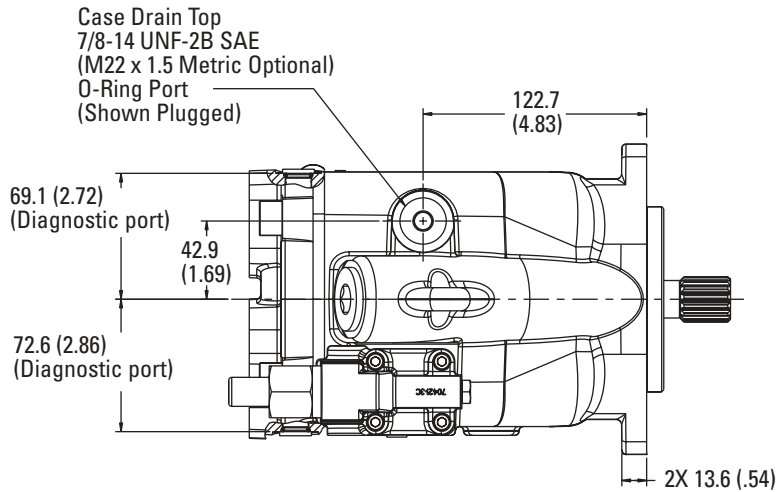

Pump Installation – Rear-Ported

420 Mobile Piston Pump

LH Rotation Flange Ports (cont.)

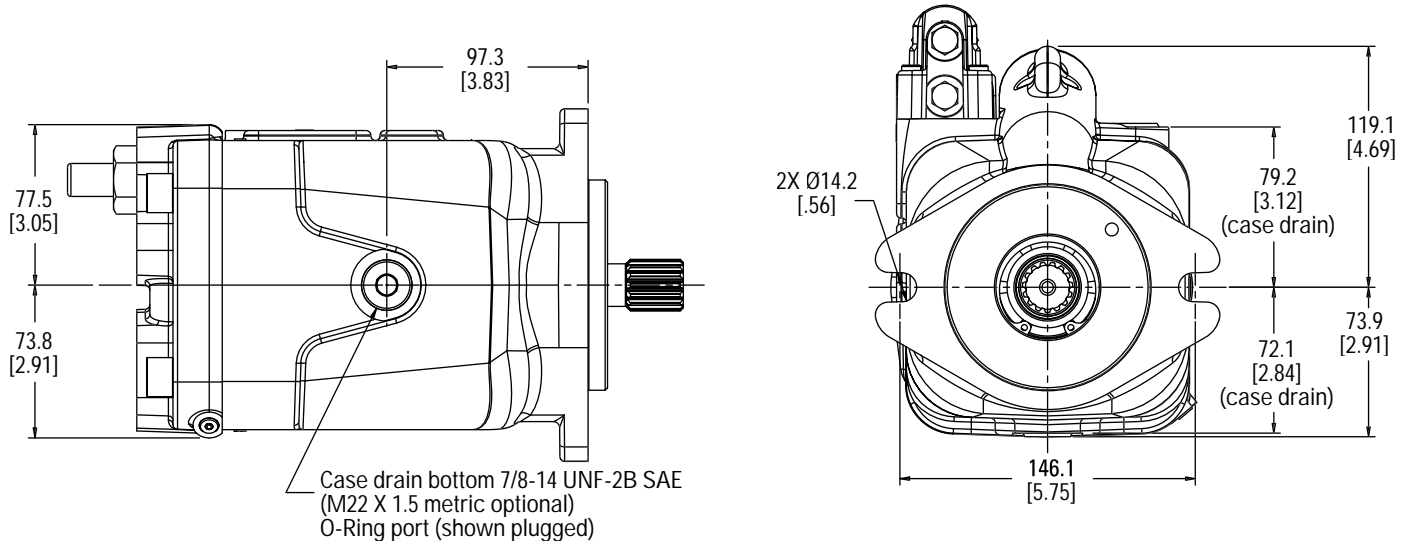

RH Rotation Flange Parts (CW)

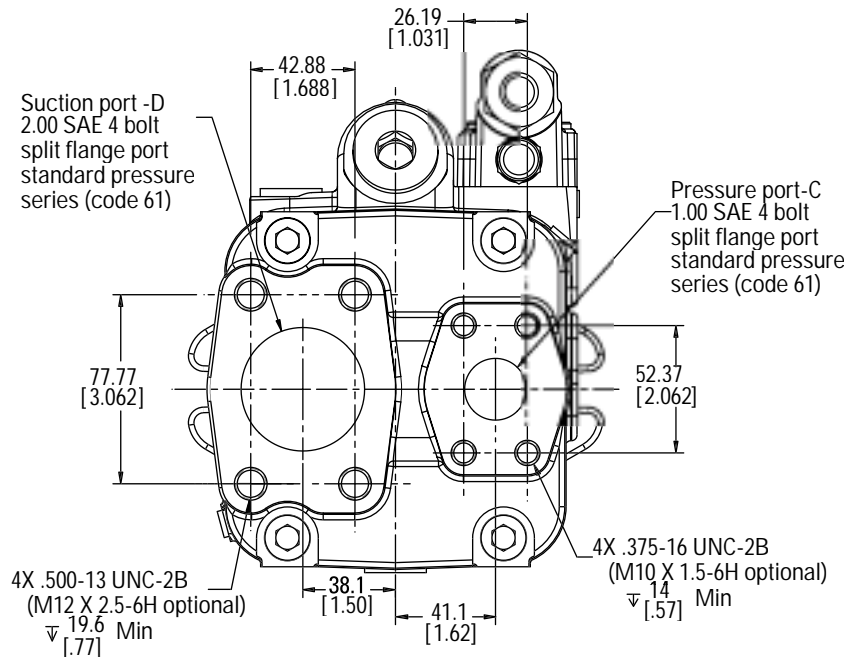

Pump Installation – Rear-Ported

420 Mobile Piston Pump

LH Rotation Tube Port

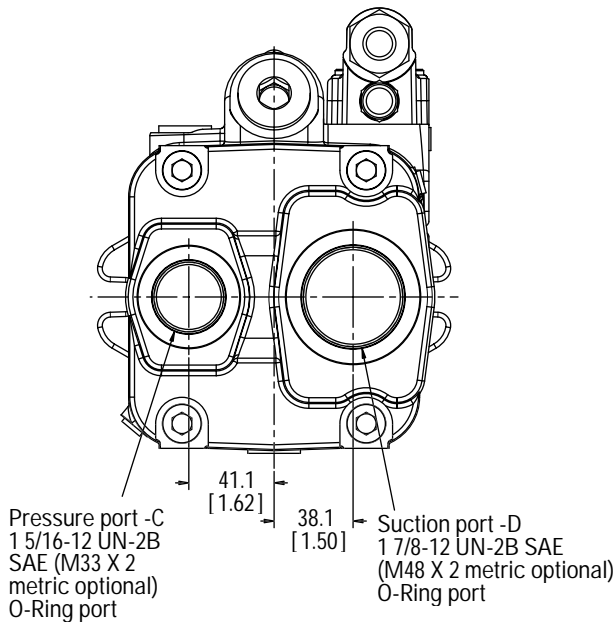

RH Rotation Tube Port

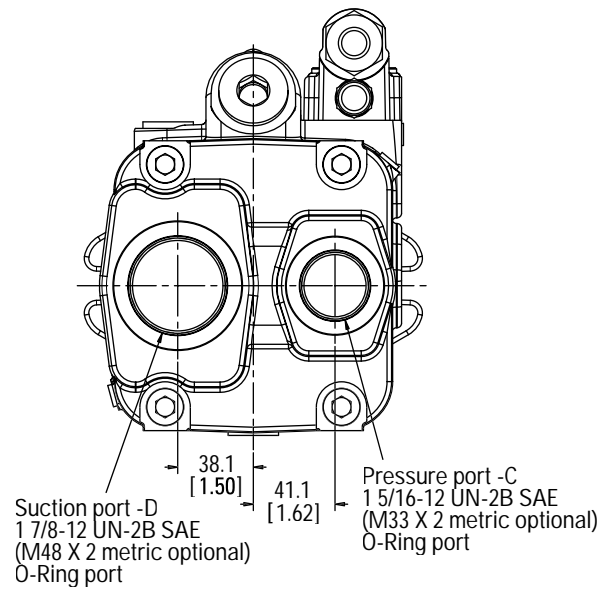

RH Rotation Flange/Tube Ports

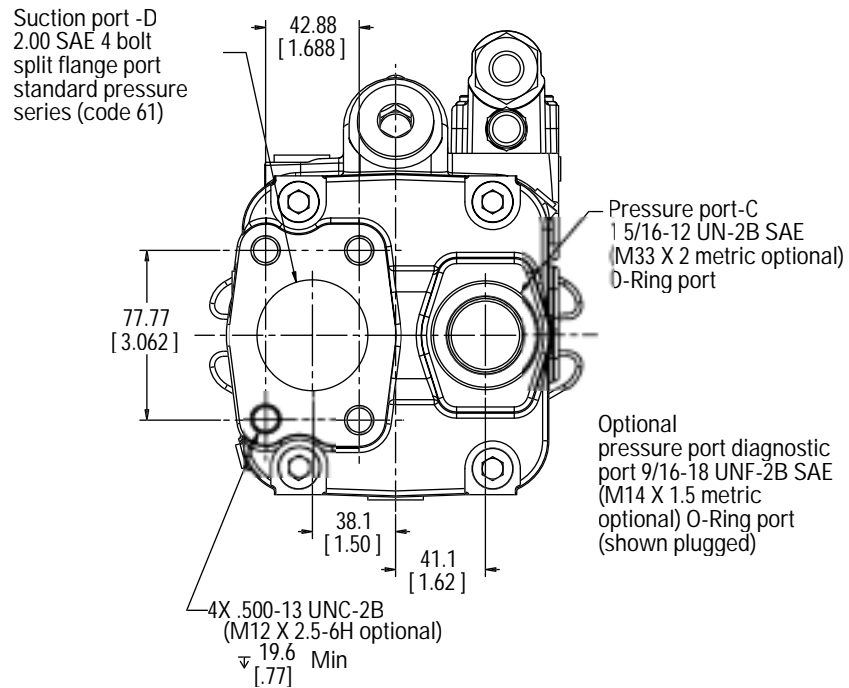

Pump Installation – Rear-Ported

420 Mobile Piston Pump

RH Rotation Diagnostic Port Outlet

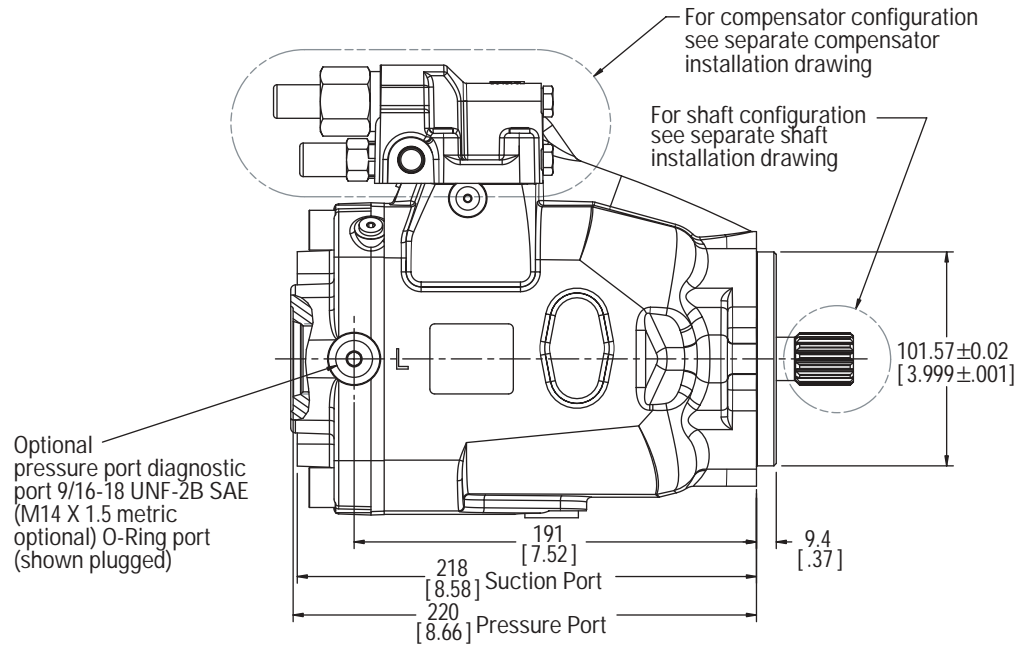

RH Rotation Diagnostic Port Inlet

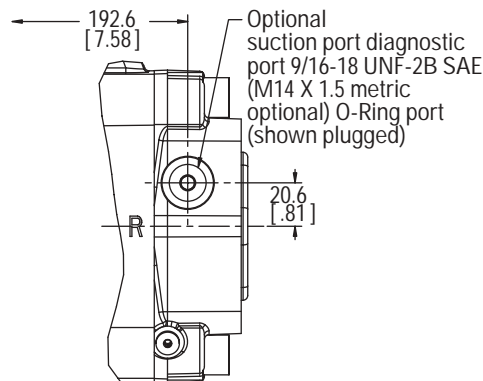

View A-A

Pump Installation – Side-Ported

420 Mobile Piston Pump

LH Rotation Flange Ports

Case Drain Top
7/8-14 UNF-2B SAE
(M22 x 1.5 Metric Optional)
O-Ring Port
(Shown Plugged)

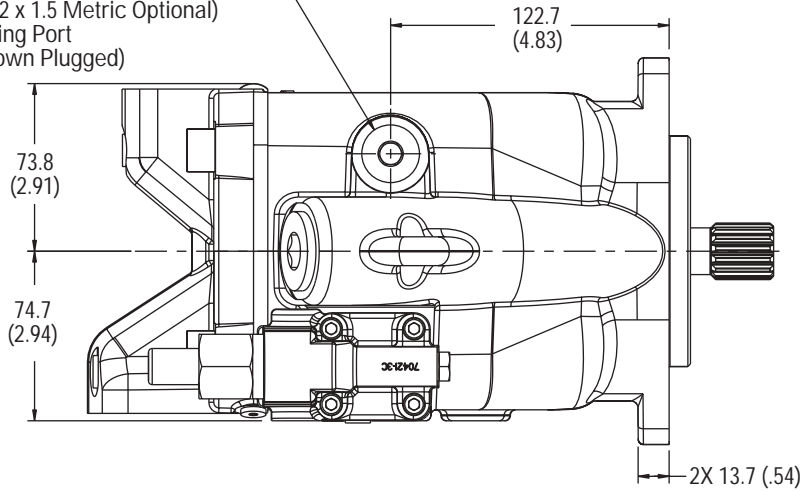

Suction
port -D
2.00 SAE 4
bolt split flange
port standard
pressure series
(code 61)

For compensator configuration
see separate compensator
installation drawing

For shaft configuration
see separate shaft
installation drawing

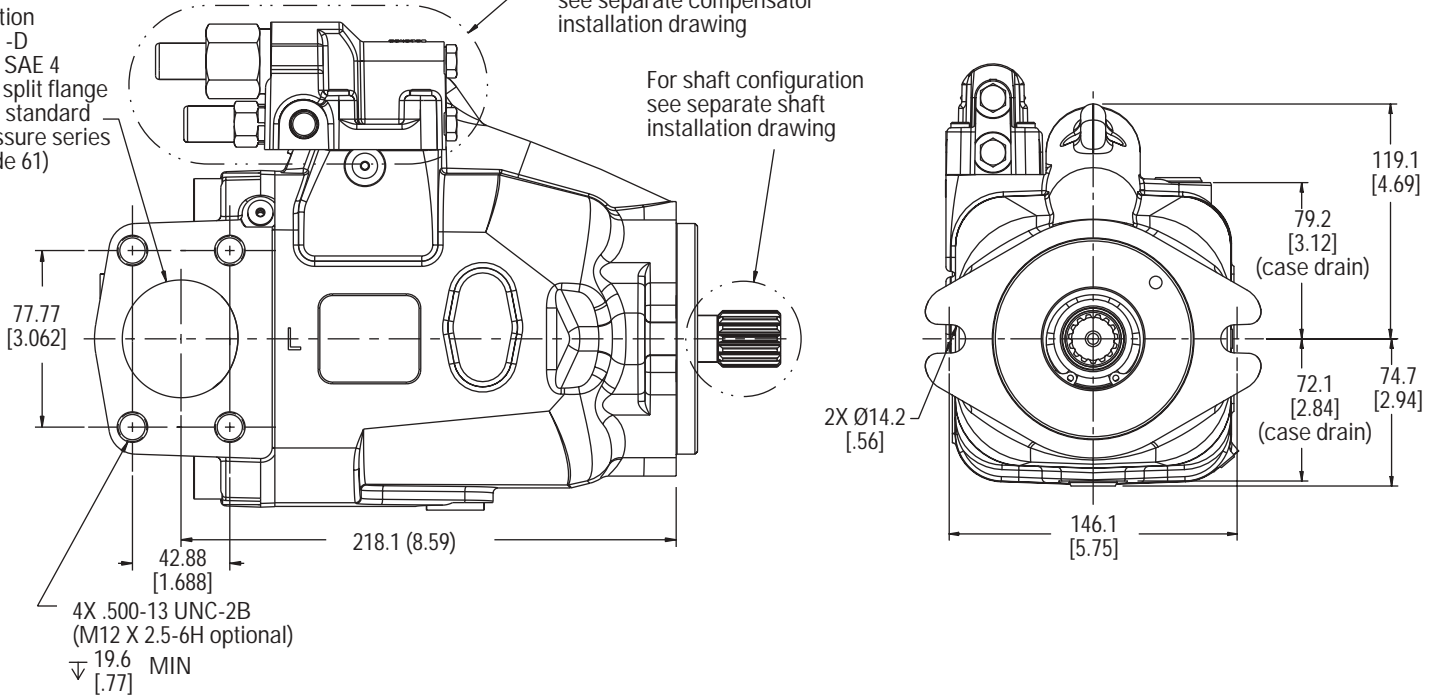

Pump Installation - Side-Ported

420 Mobile Piston Pump

LH Rotation Flange Ports

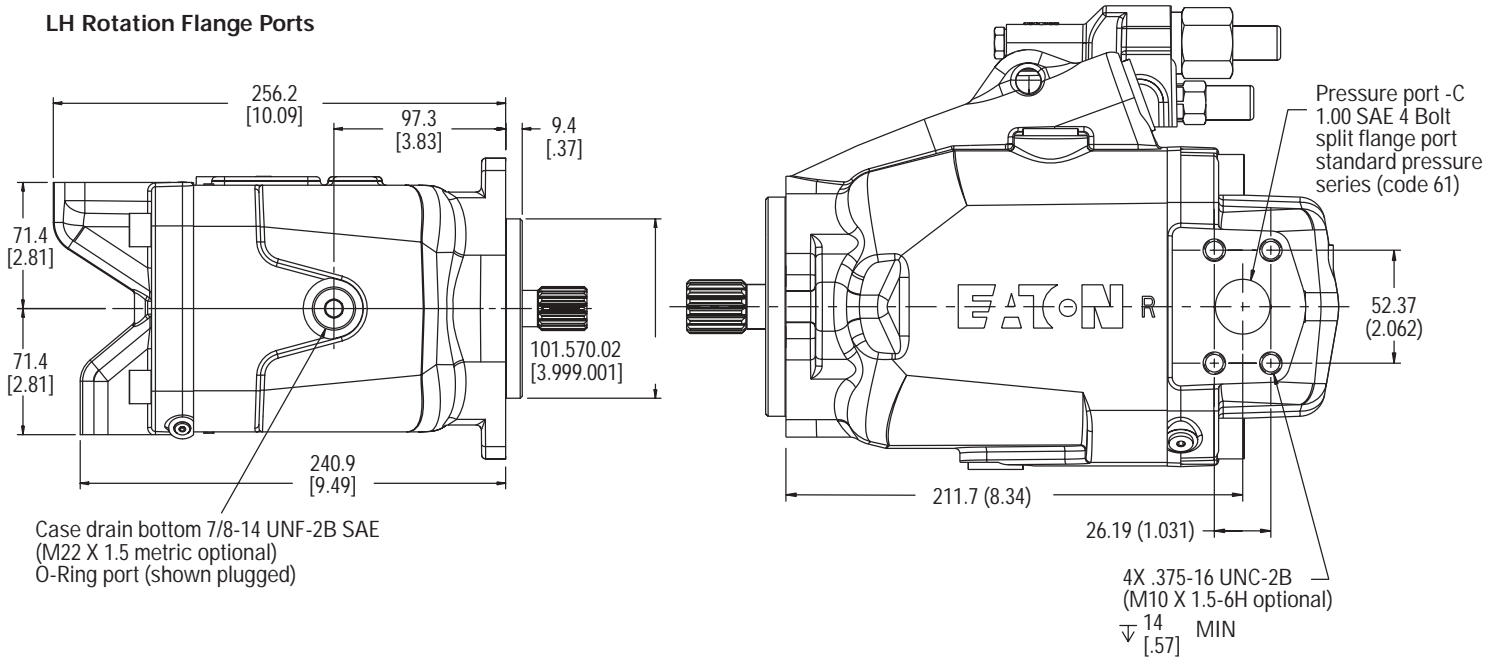

RH Rotation Flange Ports

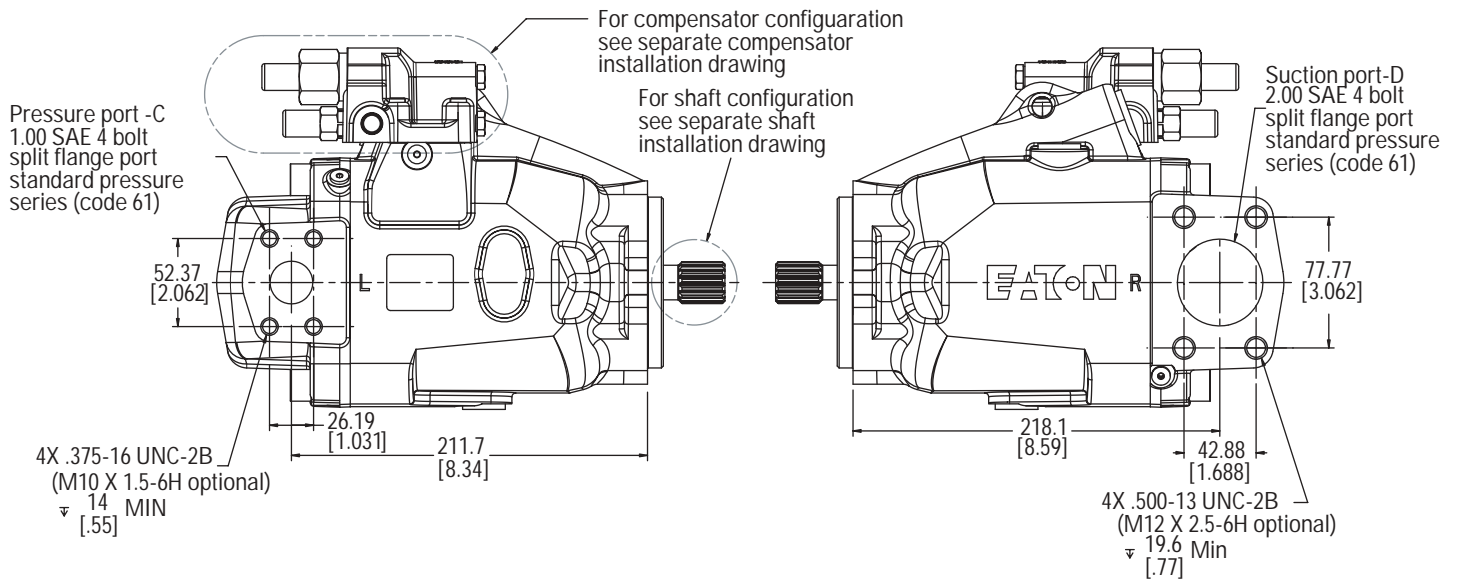

Pump Installation – Side-Ported

420 Mobile Piston Pump

LH Rotation Tube Ports

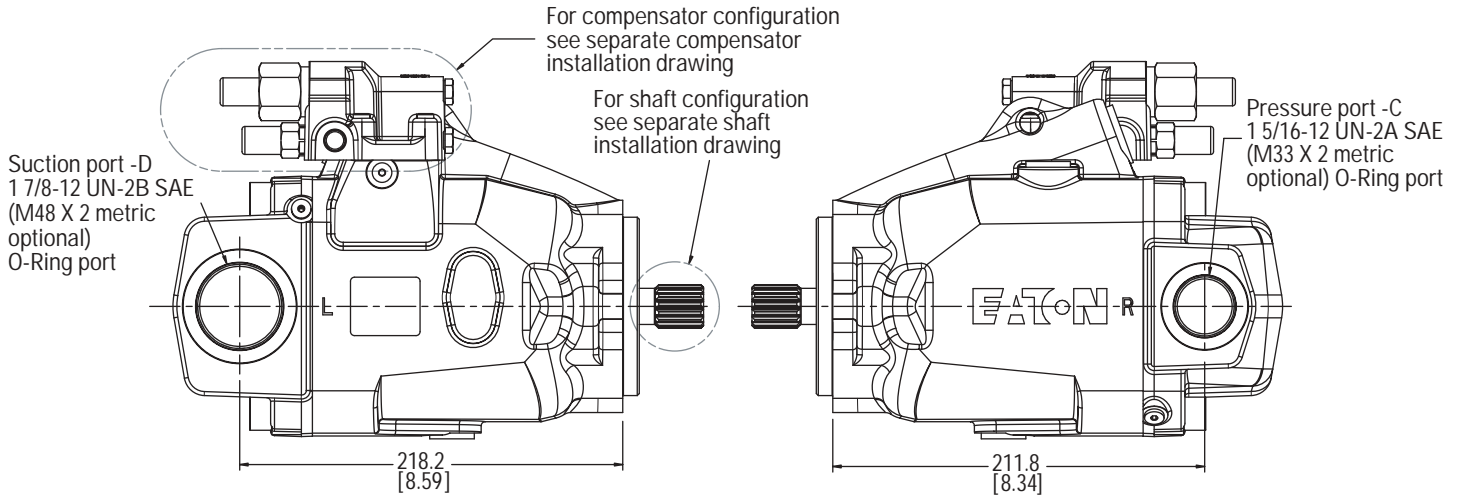

RH Rotation Tube Ports

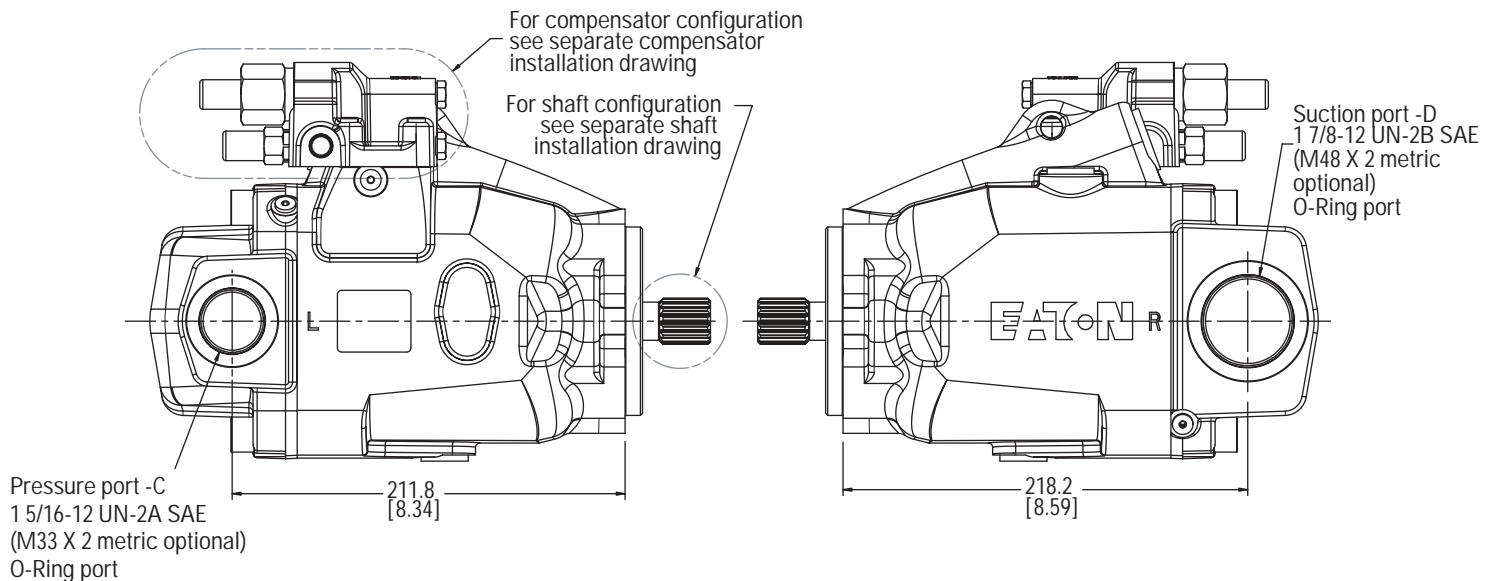

Pump Installation – Side-Ported

420 Mobile Piston Pump

RH Rotation Diagnostic Ports

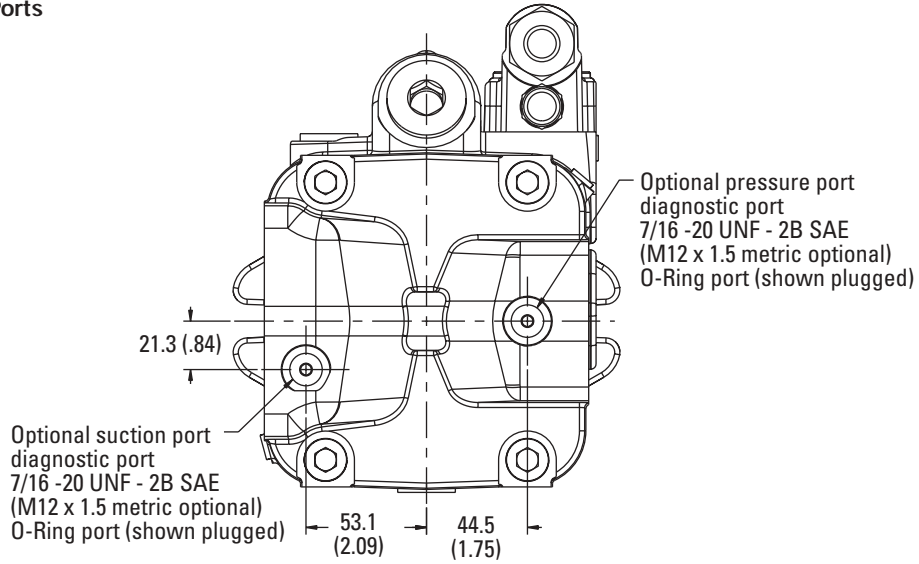

LH Rotation Diagnostic Ports

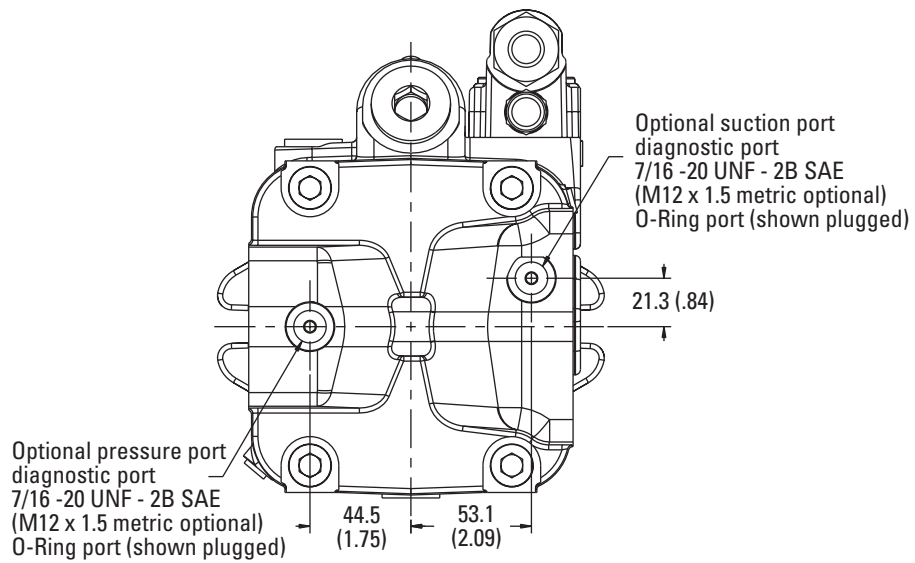

Pump Installation – Thru-Drive SAE A Option

420 Mobile Piston Pump

LH Rotation Flange Ported

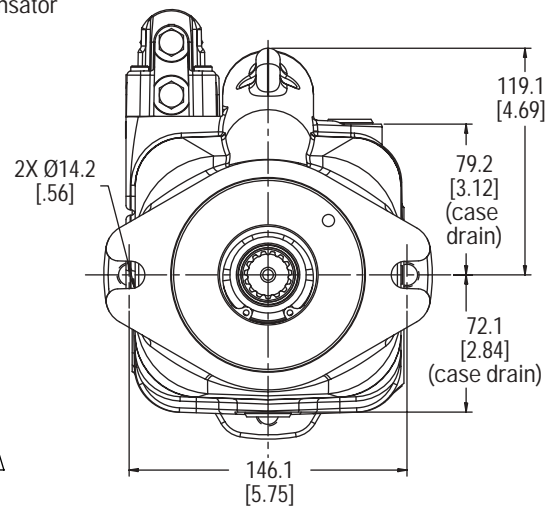
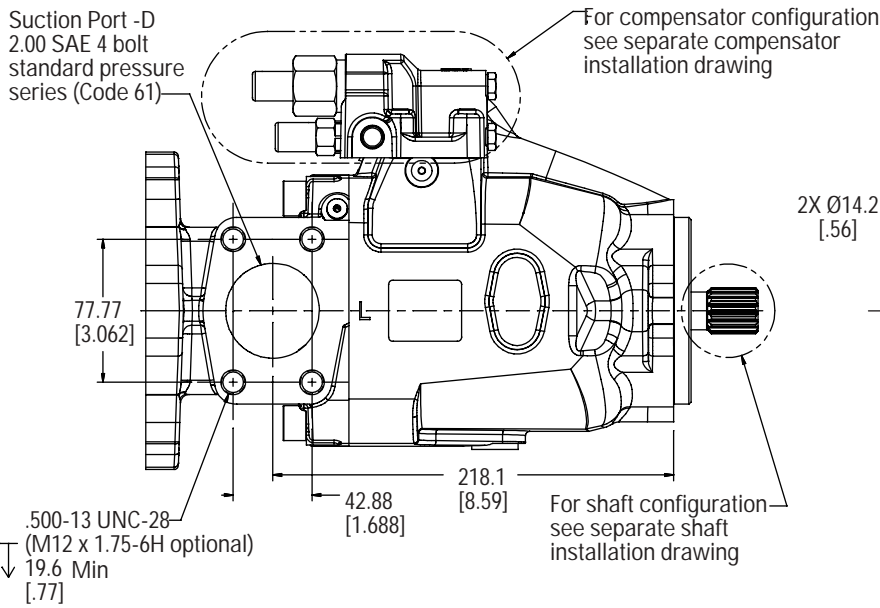
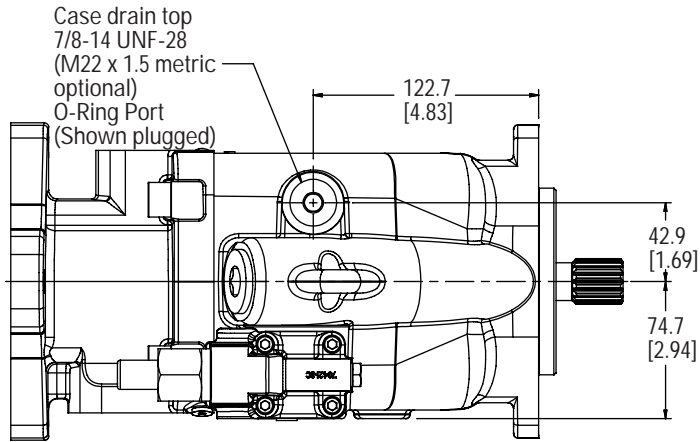

Pump Installation – Thru-Drive SAE A Option

420 Mobile Piston Pump

LH Rotation Flange Ported

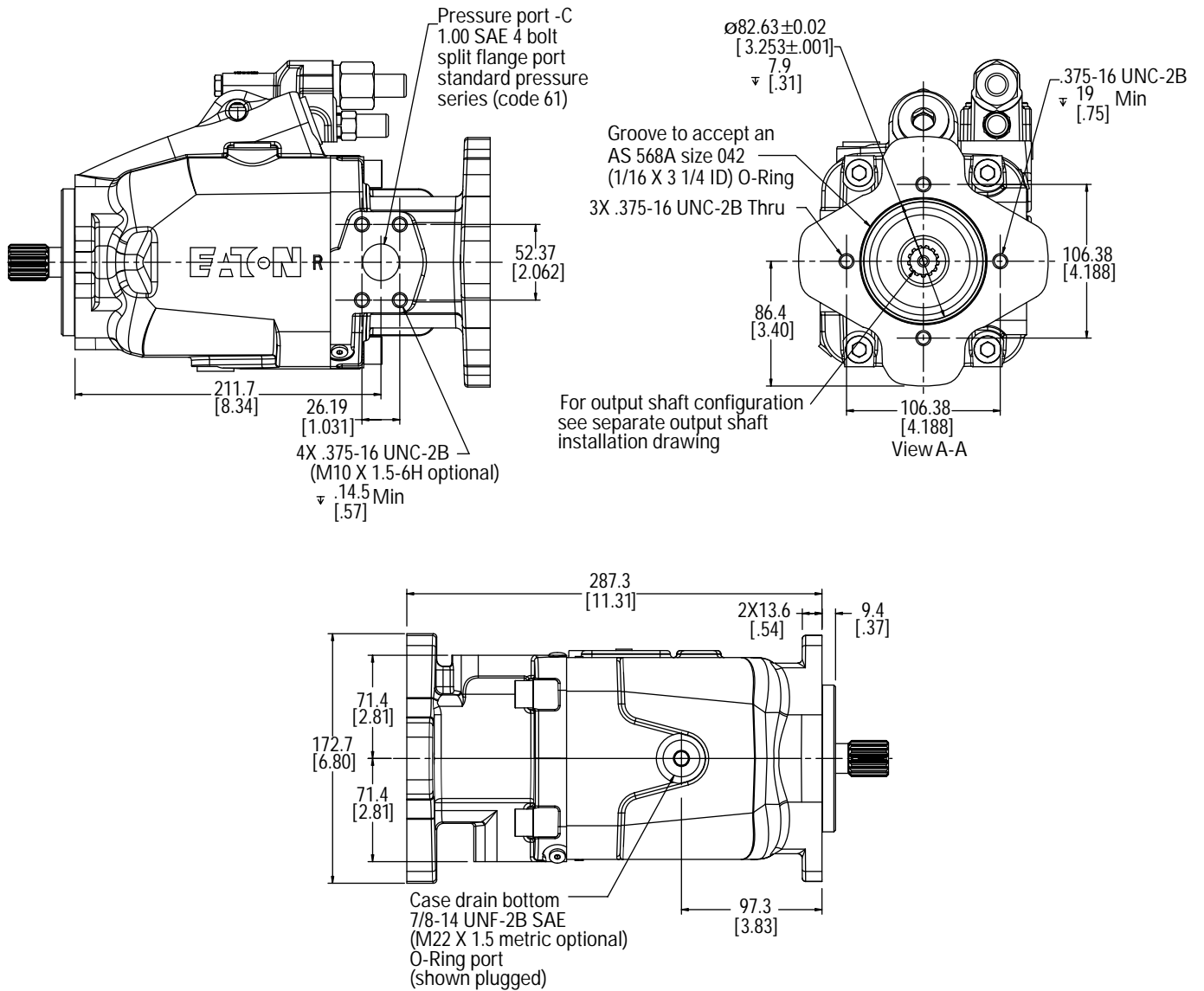

Pump Installation – Thru-Drive SAE A Option

420 Mobile Piston Pump

RH Rotation Flange Ports

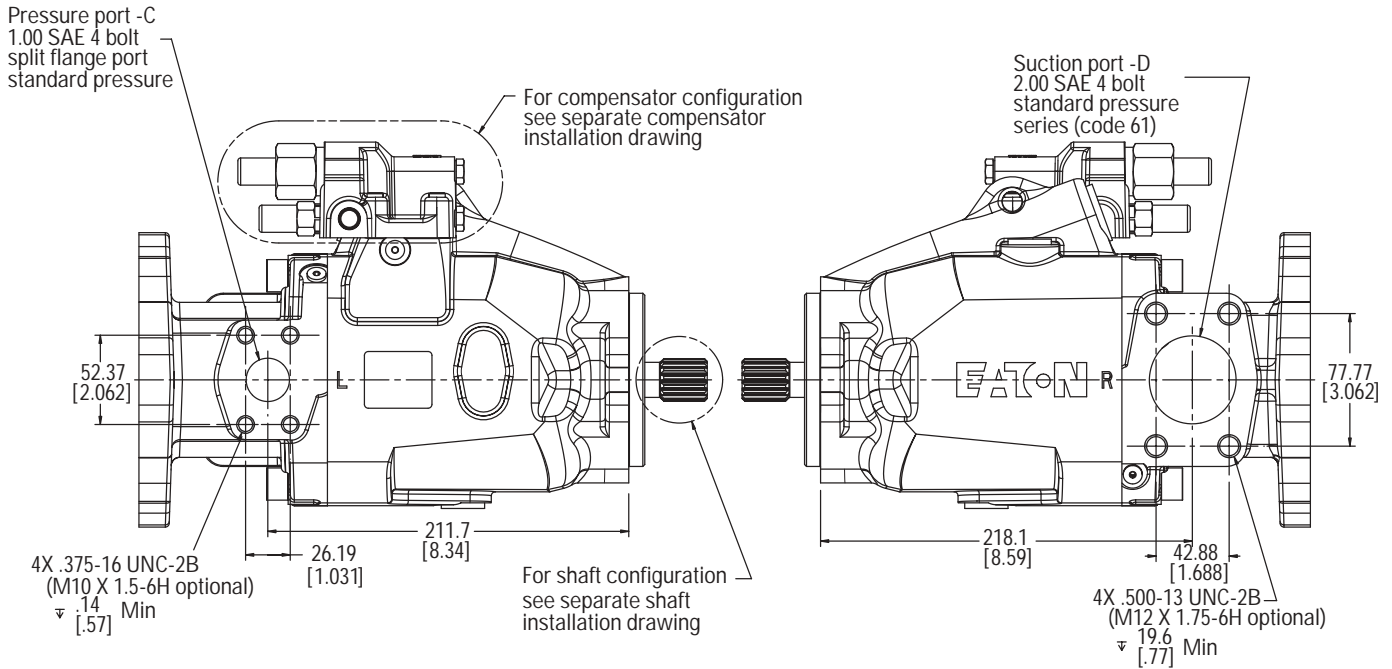

LH Rotation Tube Ports

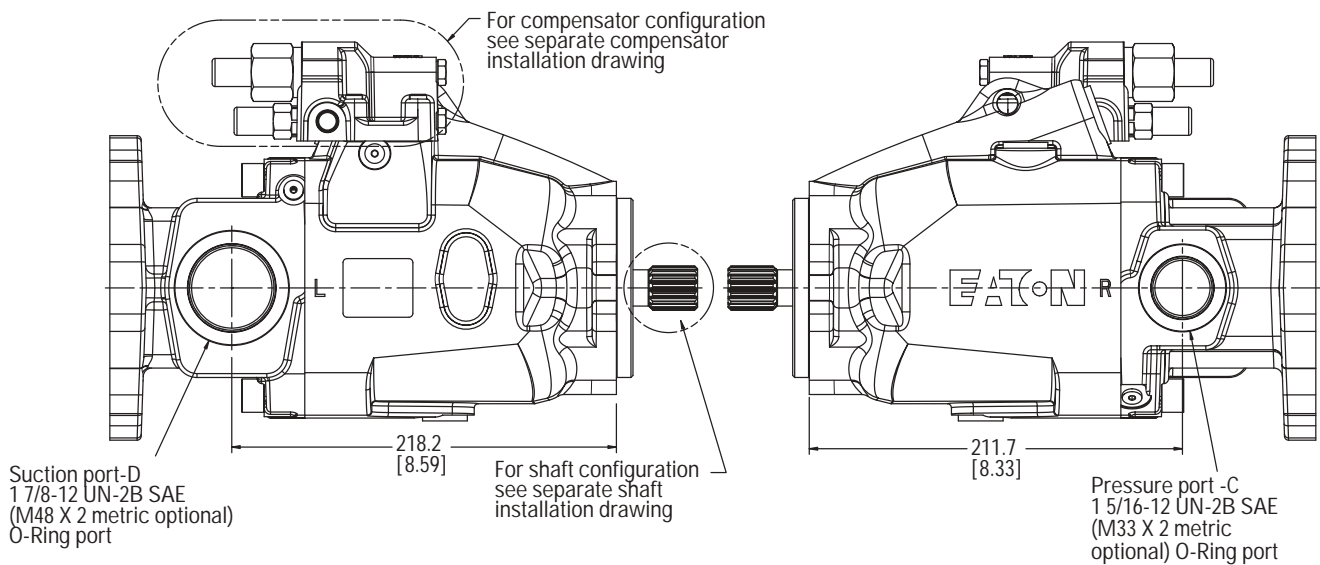

Pump Installation – Thru-Drive SAE A Option

420 Mobile Piston Pump

RH Rotation Tube Ports

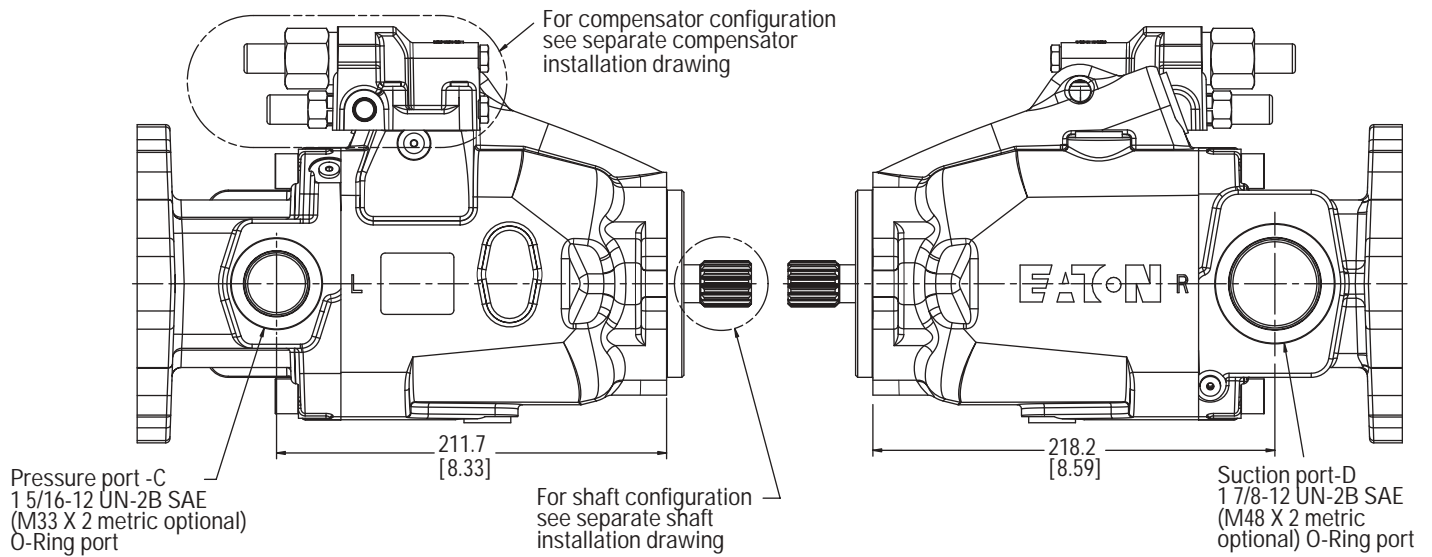

Output Shaft Installation 9T Spline

ø16.54 [.651] 9 tooth 30° flat root side fit 16/32 class 5 internal spline per ANSI B92.1

Accepts 9 tooth 30° flat root side fit 16/32 external splines per SAE J498b class 1 or ANSI B92.1 class 5 with 31.8 [1.25] extension from mounting flange

Additional units drive by this spline must not require more than 74.6 N-m [55 lbf-ft] of torque

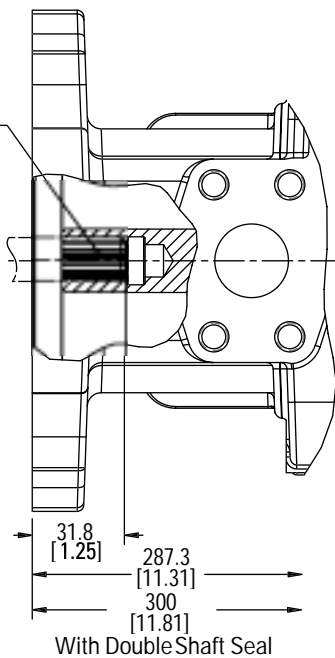

Output Shaft Installation 11T Spline

ø19.33 [.761] 11 tooth 30° flat root side fit 16/32 class 1 internal spine per SAE J498b

Accepts 11 tooth 30° flat root side fit 16/32 external splines per SAE J498b class 1 or ANSI B92.1 class 5 with 31.8 [1.25] extension from mounting flange

Additional units driven by this spline must not require more than 118.6 N-m [88 lbf-ft] of torque

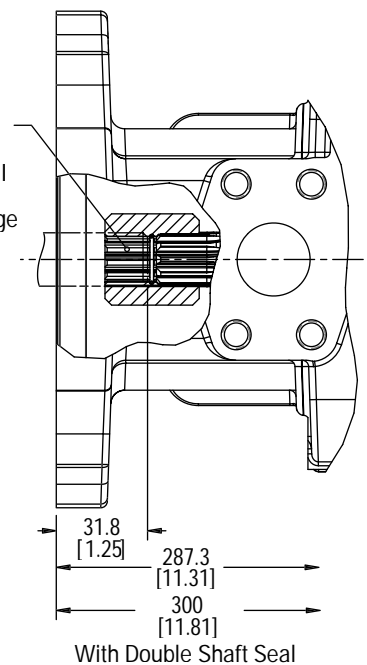

Pump Installation – Thru-Drive SAE A Option

420 Mobile Piston Pump

A Thru-Drive Cover Plate Installation

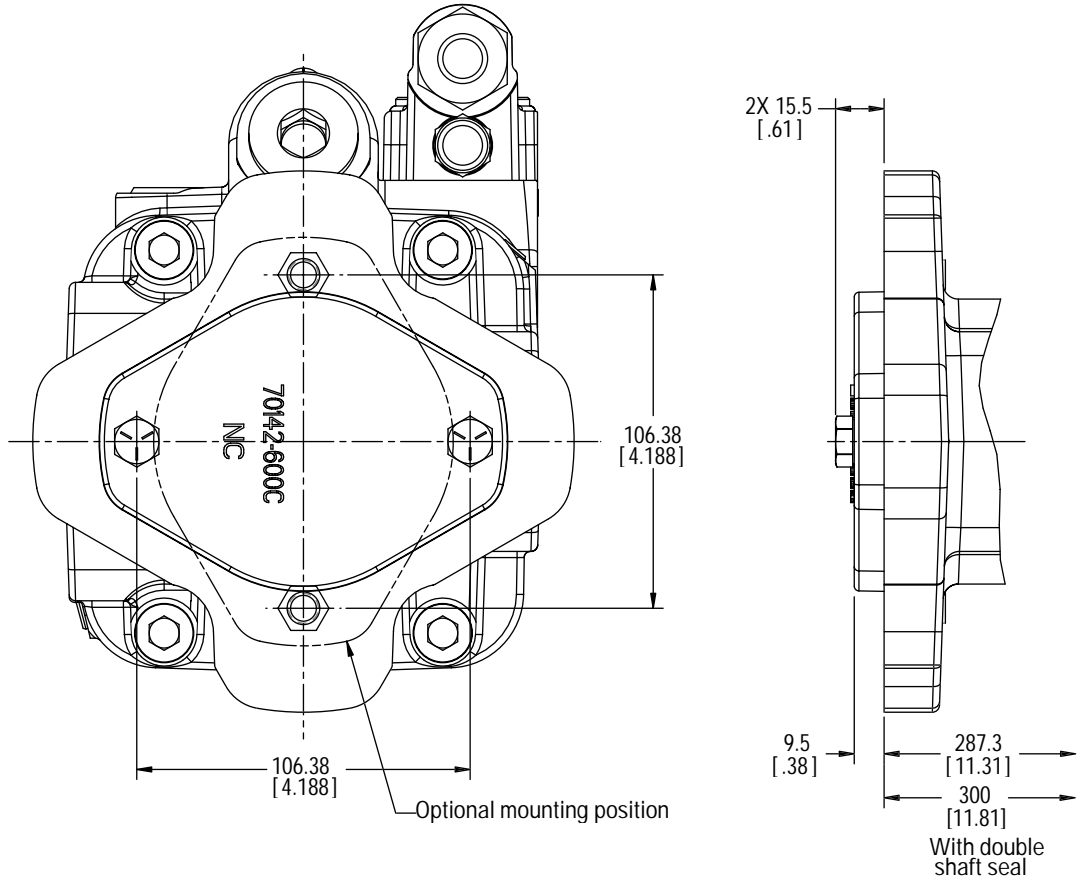

Pump Installation – Thru-Drive SAE B Option

420 Mobile Piston Pump

LH Rotation Flange Ports

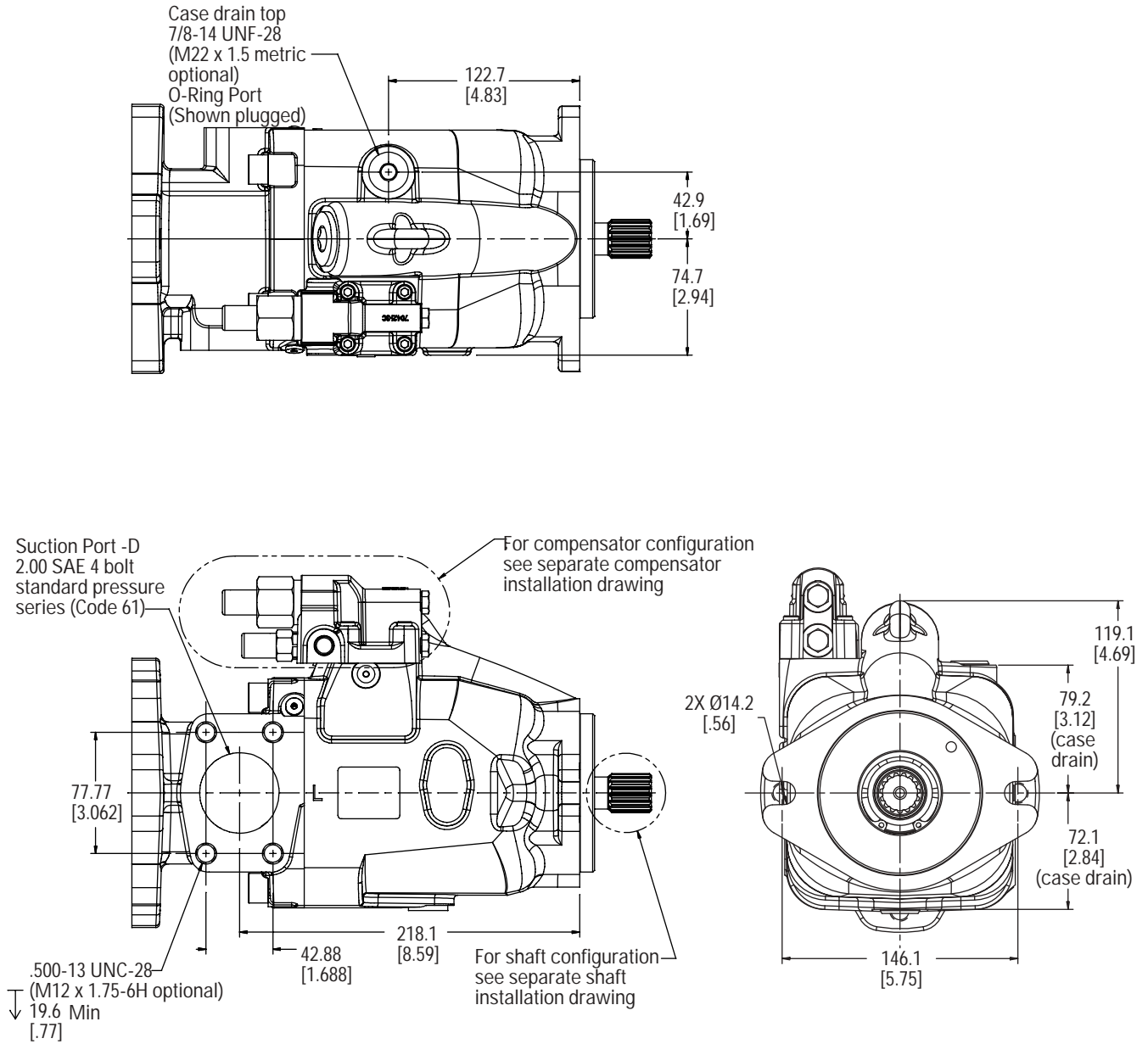

Pump Installation – Thru-Drive SAE B Option

420 Mobile Piston Pump

LH Rotation Flange Ports

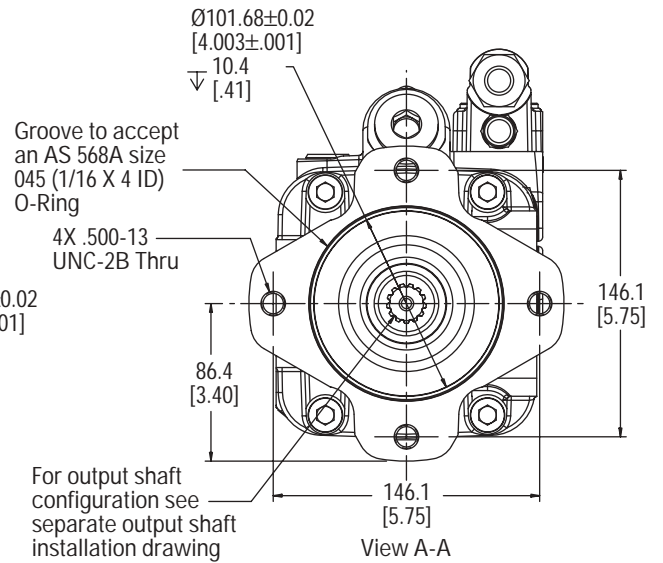
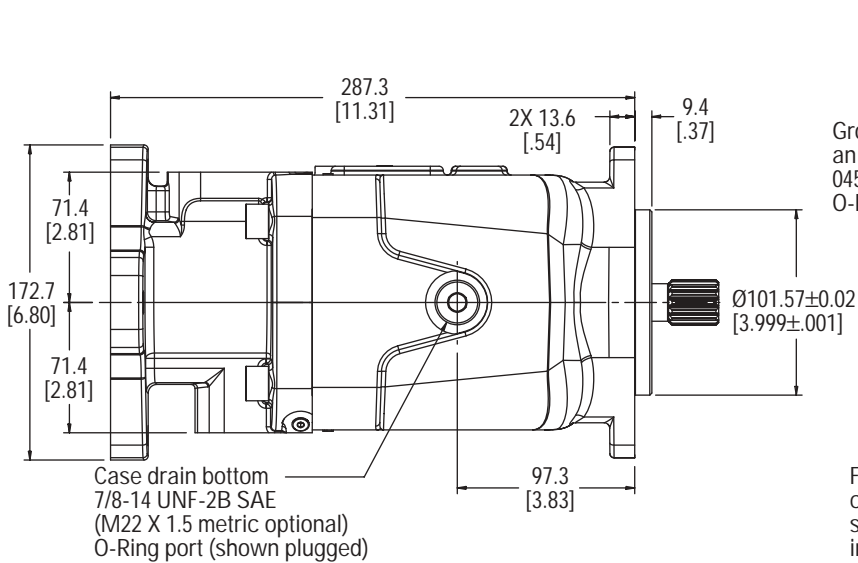
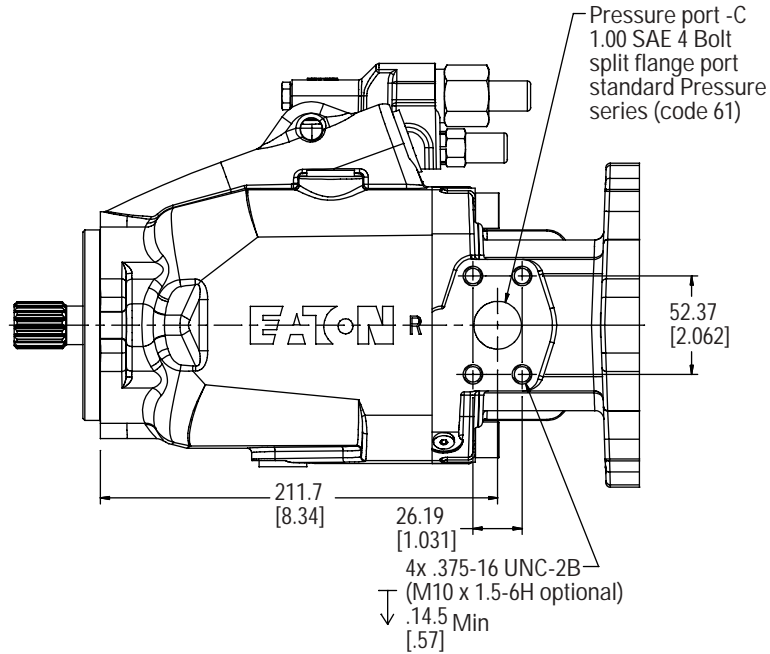

Pump Installation – Thru-Drive SAE B Option

420 Mobile Piston Pump

RH Rotation Flange Ports

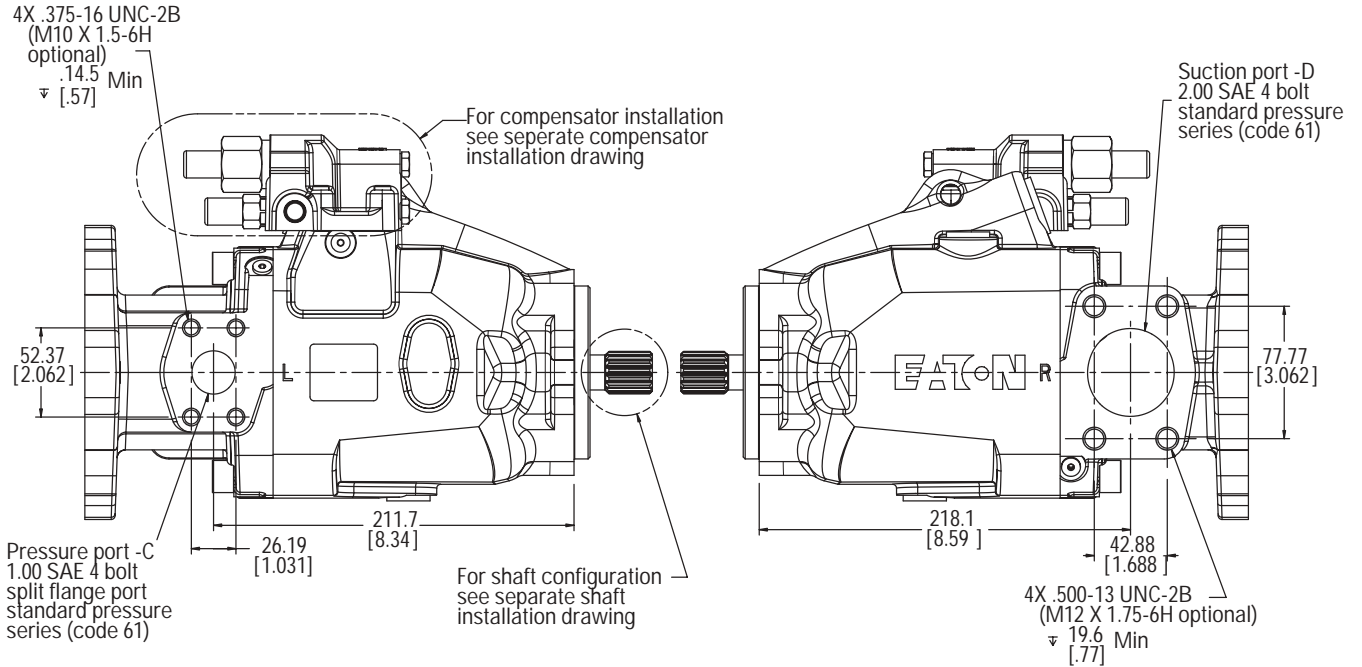

LH Rotation Tube Ports

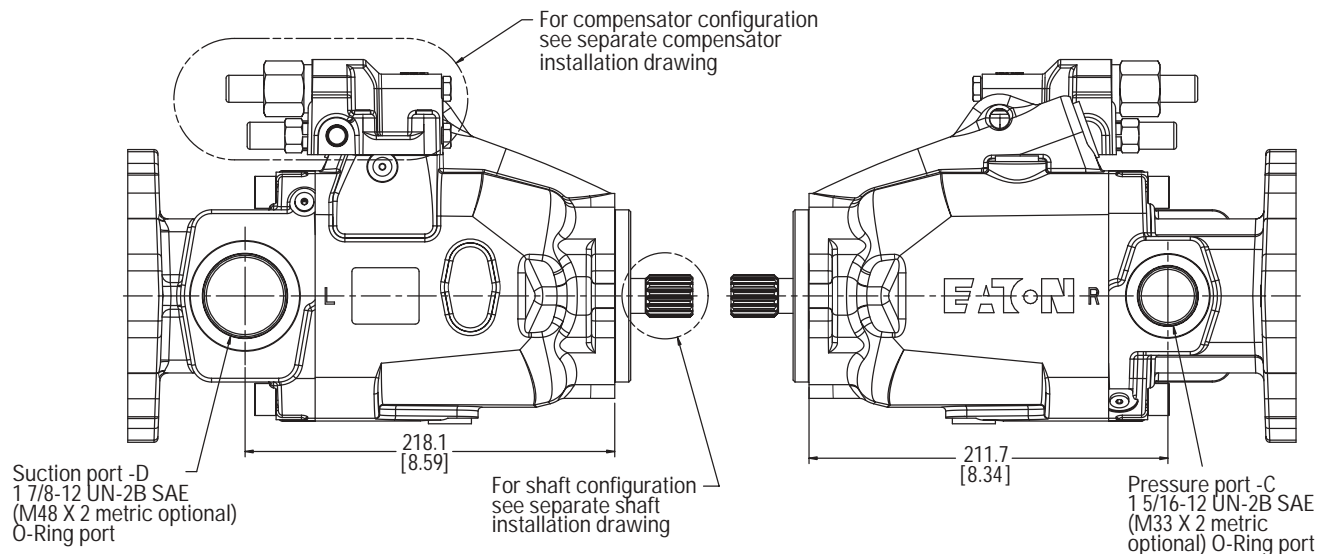

Pump Installation – Thru-Drive SAE B Option

420 Mobile Piston Pump

RH Rotation Tube Ports

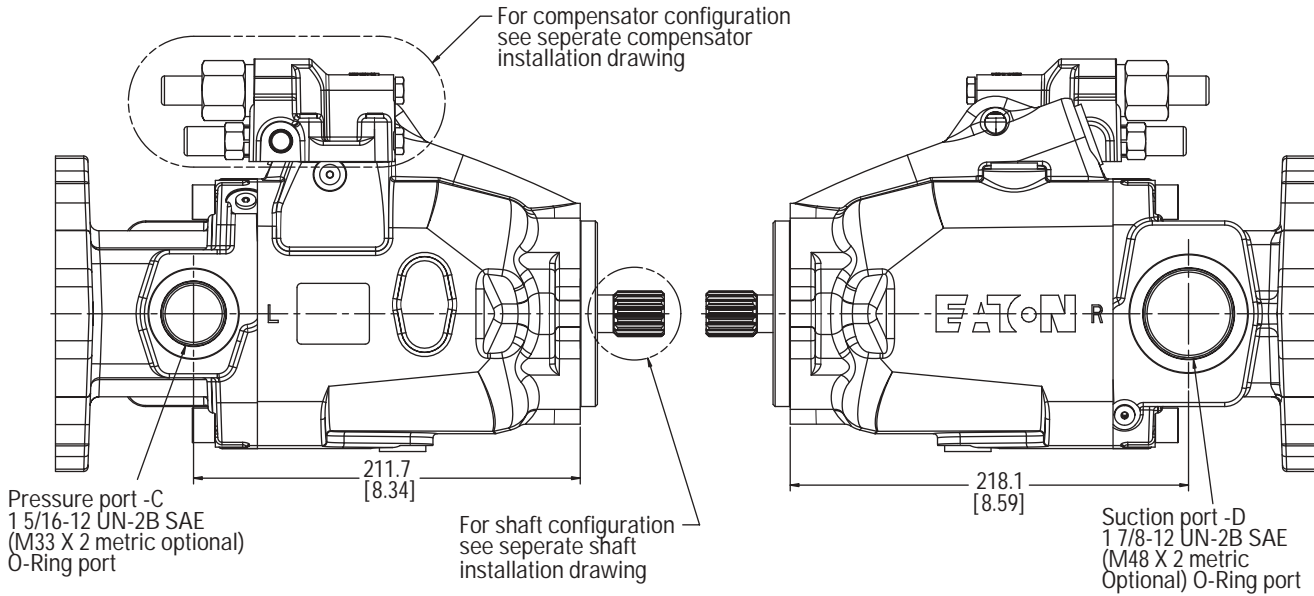

Output Shaft Installation

ø22.5 [.886] 13 tooth 30° flat root side fit 16/32 class 1 internal spline per SAE J498b
Accepts 13 tooth 30° flat root side fit 16/32 external splines per SAE J498b class 1 or ANSI B92.1 class 5 with 41.2 [1.62] extension from mounting flange

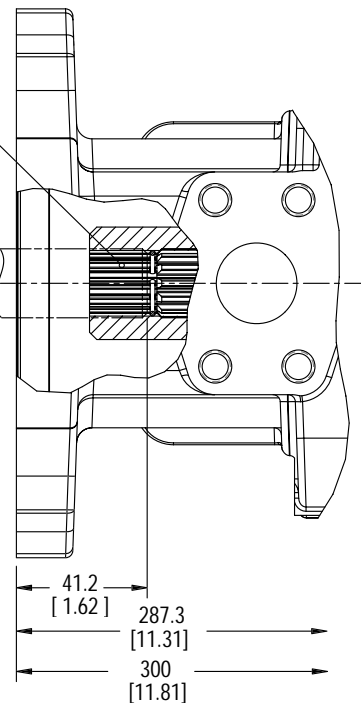

With Double Shaft Seal

Pump Installation – Dual Shaft Seal Option

420 Mobile Piston Pump

**Model Code Position 26
Option "3"**

Case drain top
7/8-14 UNF-2B SAE
(M22 x 1.5 metric
optional) O-ring port
(shown plugged)

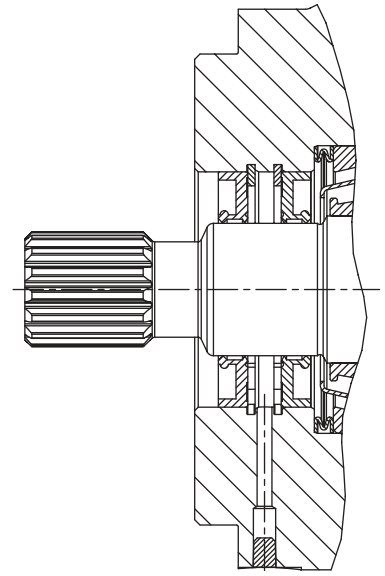
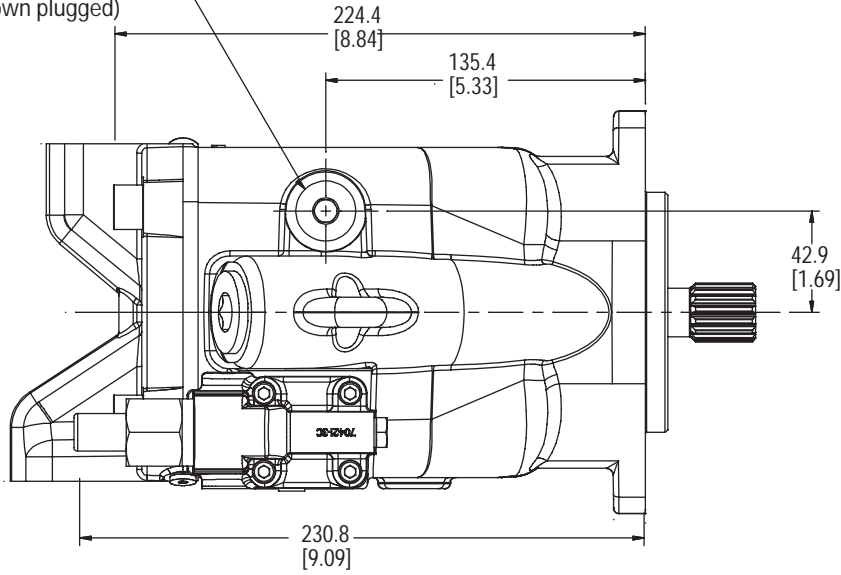

Cross section of dual
shaft seal assembly

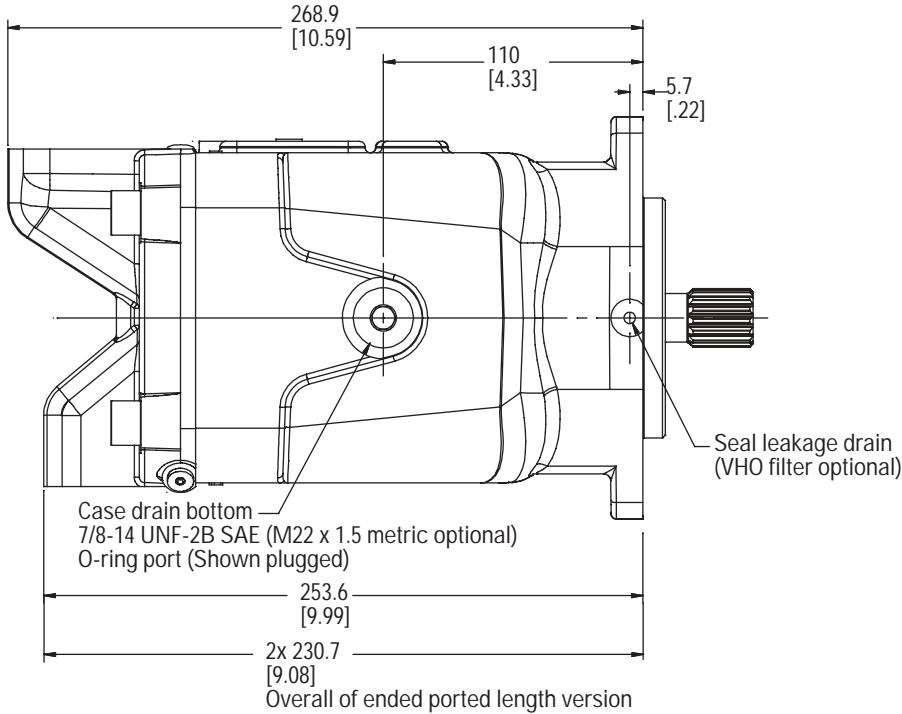

Pump Installation – External Manual Stroke Adjustment

420 Mobile Piston Pump

Maximum Stroke Limiter

1 1 turn clockwise reduces maximum displacement approximately 5.5% (1° stroke)

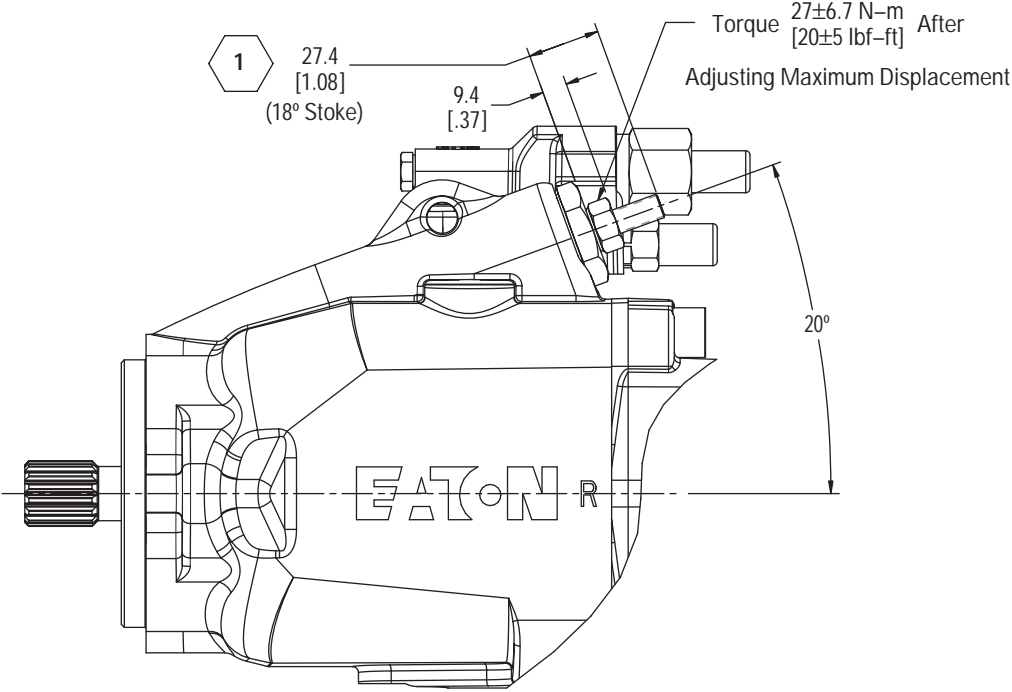

Reference A-2448-001

Pump Control Installation

420 Mobile Piston Pump

Pressure Flow Compensator
Control Code (A) or (B)

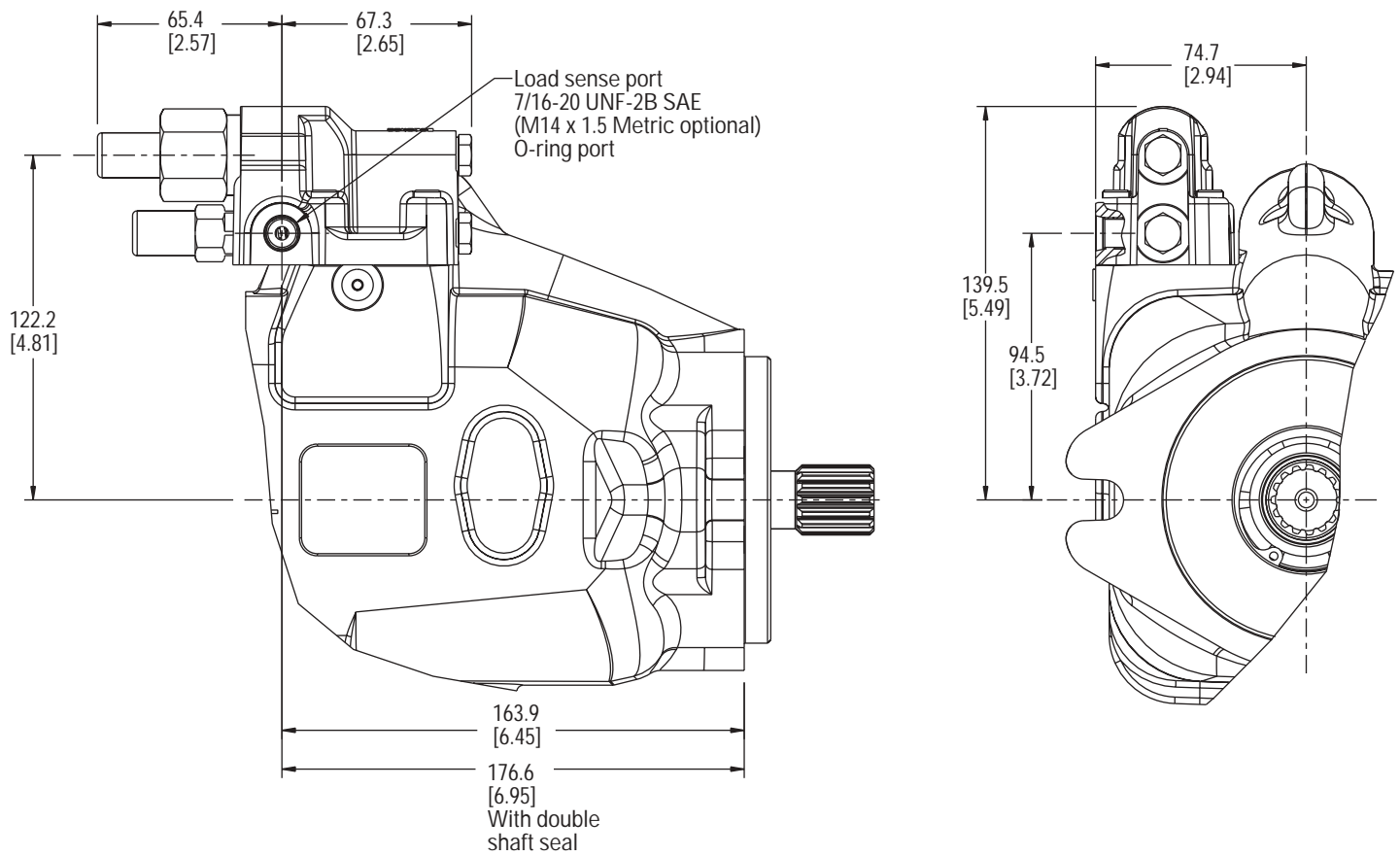

Pump Control Installation

420 Mobile Piston Pump

Pressure Compensating
Control Code (C)

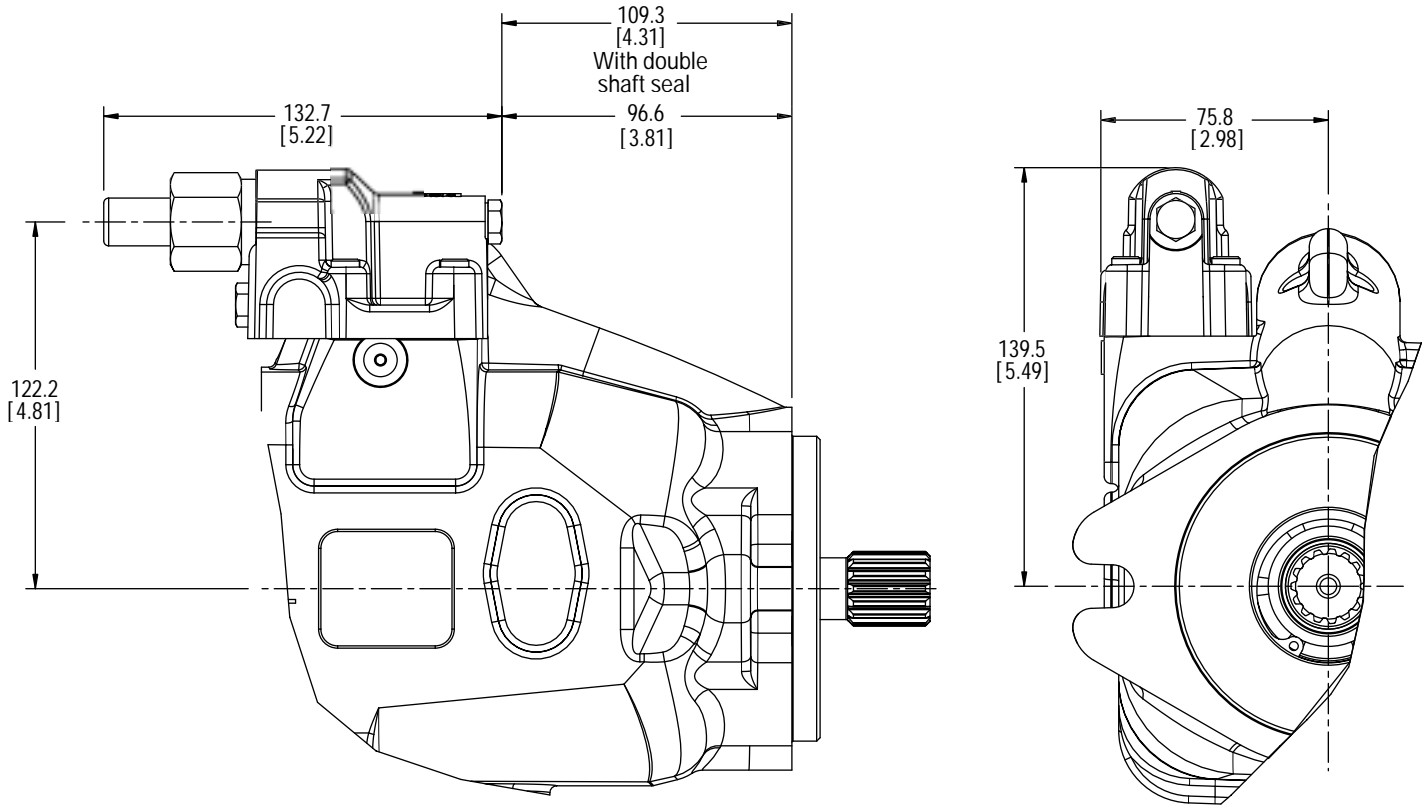

Shaft Options

01 Code

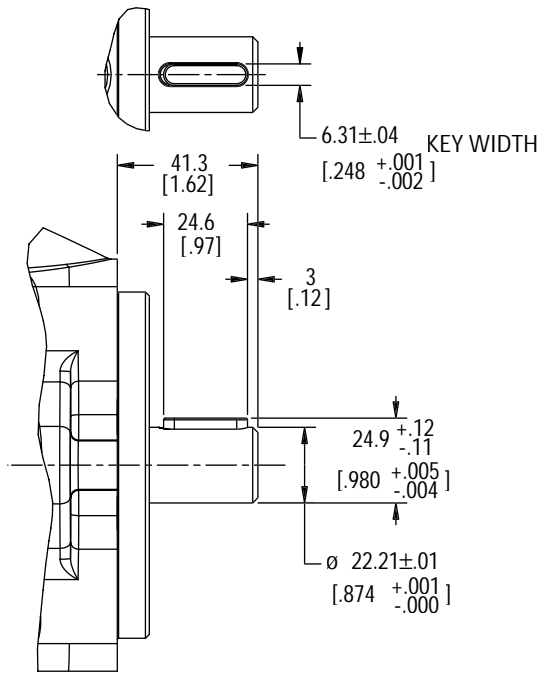

02 Code

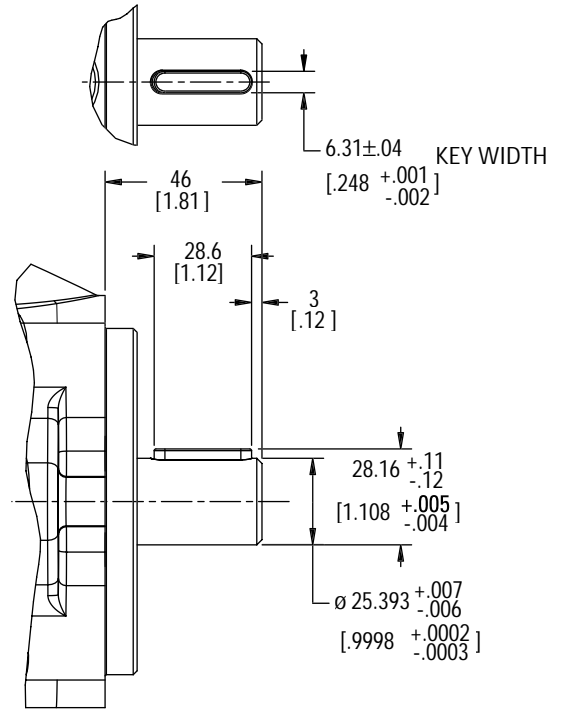

04 Code

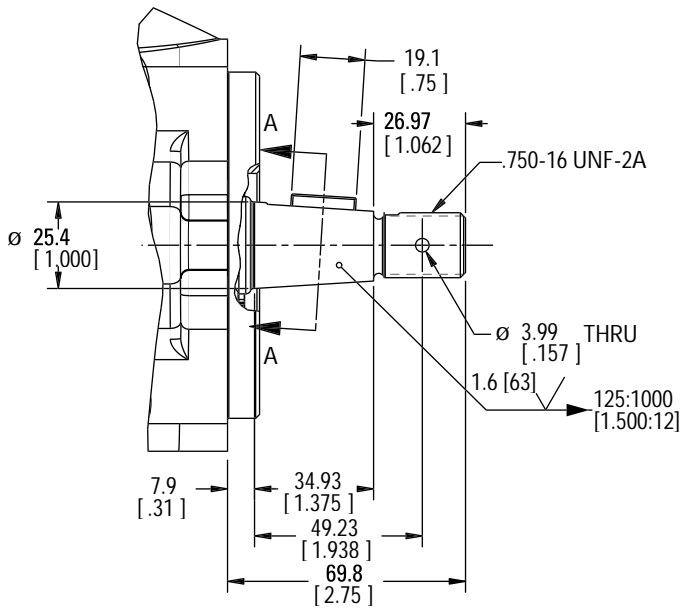

05 Code

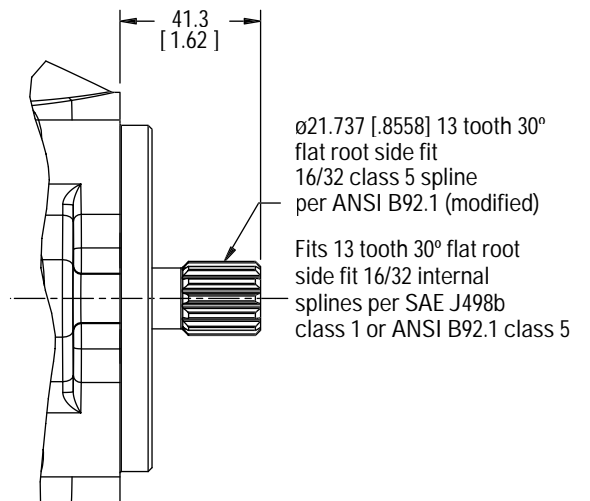

Shaft Options

08 Code

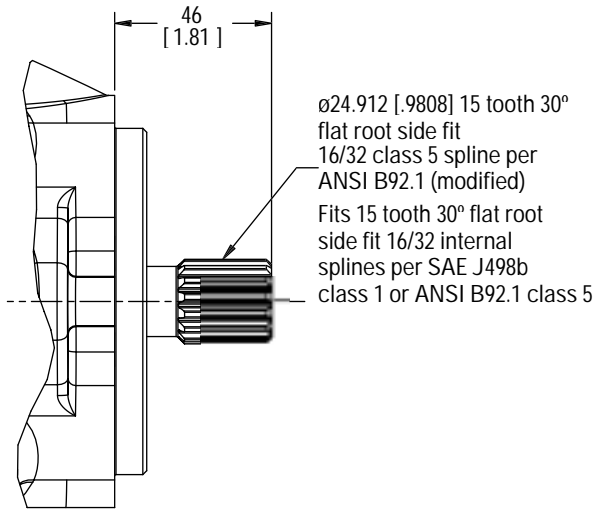

30 Code

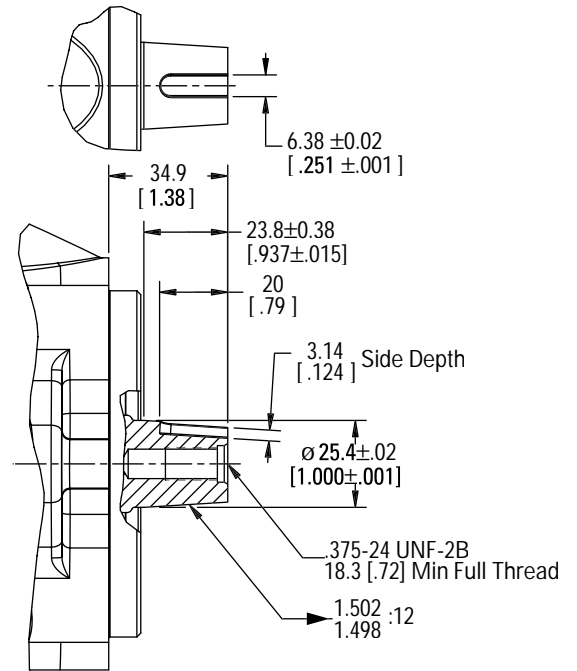

31 Code

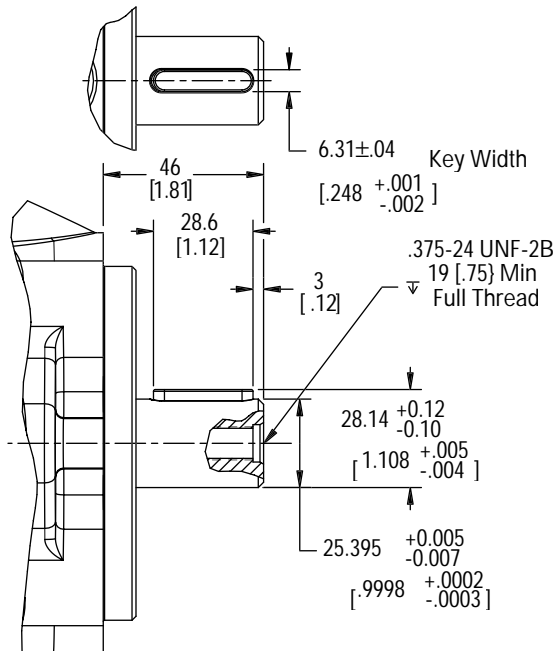

Side Loads

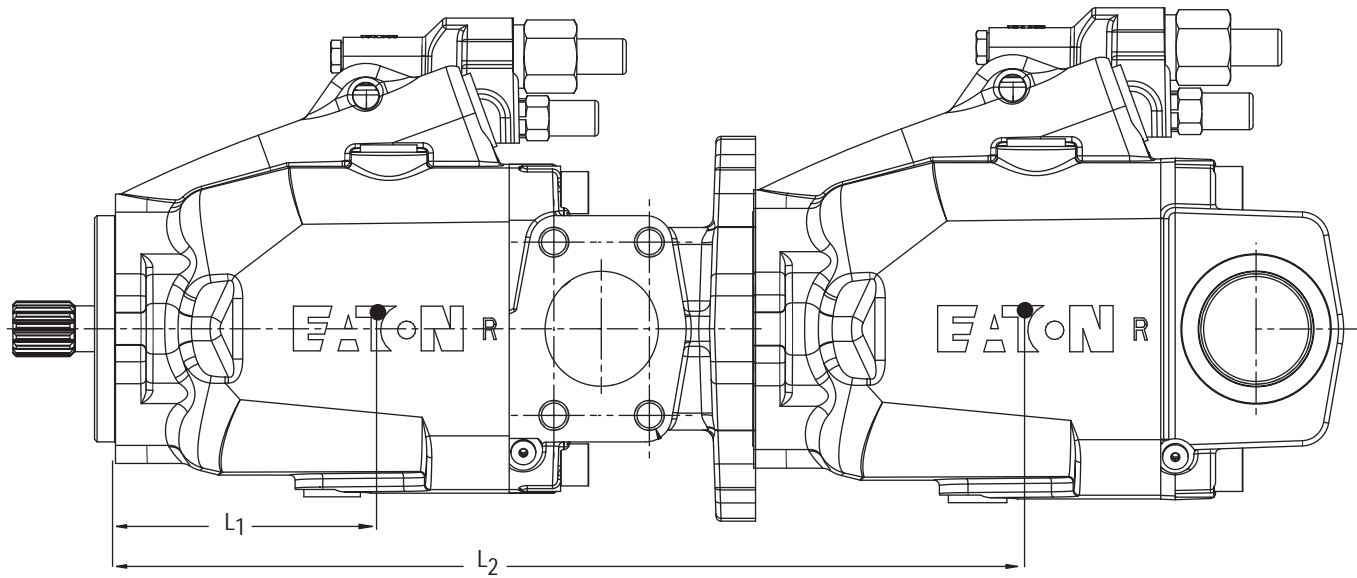

Center of Gravity

	REAR	SIDE	THRU-DRIVE	DUAL SEAL	THRU-DRIVE LENGTH
	Lcg			Lds	Lt
ADU041	110 (4.32)	115 (4.52)	132 (5.18)	13 (.50)	287 (11.31)
ADU049	110 (4.32)	115 (4.52)	132 (5.18)	13 (.50)	287 (11.31)
ADU062	110 (4.32)	115 (4.52)	132 (5.18)	13 (.50)	287 (11.31)

Examples: Calculation L₁ and L₂

Tandem ADU062 Thru-drive with ADU041 Rear Ported

$$L_1 = L_{cg} \quad 132\text{mm (5.18 inches)}$$

$$L_2 = L_t + L_{cg} \quad 132\text{mm} + 110\text{mm} = 242\text{mm (9.53 inches)}$$

Tandem Dual Seal ADU049 Thru-drive with ADU049 Side Ported

$$L_1 = L_{cg} + L_{ds} \quad 132\text{mm} + 13\text{mm} = 146\text{mm (5.75 inches)}$$

$$L_2 = L_t + L_{ds} + L_{cg} \quad 132\text{mm} + 13\text{mm} + 155\text{mm} = 260\text{mm (10.24 inches)}$$

Tandem Pump Applications

Eaton recommends that tandem pump applications be provided with additional support to limit overhung loading of the mounting flange. The Thru-drive alternate attachment points on the rear flange may be used with a customer designed support.

Torque Values and Bearing Loads

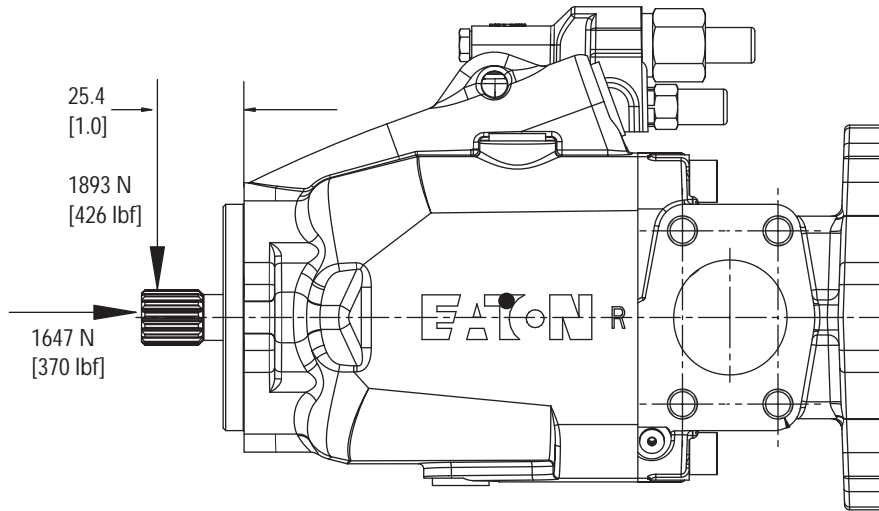

INPUT SHAFT	INPUT MOUNT	MAXIMUM INPUT TORQUE NM (IN-LBF)	AVAILABLE OUTPUT NM (IN-LBF)	AUX. MOUNT
13T	SAE B	307 (2717)	No Thrudrive	-
15T	SAE B	397 (3514)	75 (660)	SAE A 9T
15T	SAE B	397 (3514)	119 (1056)	SAE A 11T
15T	SAE B	397 (3514)	397 (3514)	SAE B 13T

Maximum Input Torque value for Input Shaft and Mount must not be exceeded.

The combined torque of a front and rear pump tandem must not exceed the Maximum Torque.

The rear pump torque must not exceed the Available Output Torque value.

420 Series Bearing Life (B10, hours)

BEARING LIFE (RATED SPEED)

bar (psi)	ADU041	ADU049	ADU062
140 (2030)	103,650	55,580	33,500
210 (3045)	26,830	14,380	8,670
250 (3625)	15,000	8,040	4,850
280 (4060)	10,280	5,510	3,320
320 (4640)	6,590	3,530	2,130

BEARING LIFE (1800 RPM)

bar (psi)	ADU041	ADU049	ADU062
140 (2030)	152,600	81,820	48,400
210 (3045)	39,500	21,180	12,500
250 (3625)	22,090	11,840	7,000
280 (4060)	15,140	8,120	4,800
320 (4640)	9,700	5,200	3,070

Operating Requirements

INLET PRESSURE, CASE PRESSURE, AND OPERATING TEMPERATURE REQUIREMENTS

Inlet Pressure			Case Pressure			Operating Temperature		
Rated Absolute bar (psi)	Minimum bar, absolute (in. Hg)	Maximum Gauge bar (psi)	Maximum Continuous bar (psi)	Maximum Intermittent bar (psi)	Peak bar (psi)	Rated °C (°F)	Minimum Temperature °C (°F)	Maximum Intermittent °C (°F)
1.0 (14.5)	0.85 (5)	3.5 (50)	1.7 (25)	5 (75)	6 (90)	93 (200)	-37 (-35)	104 (220)

HYDRAULIC FLUIDS

Fluid	Recommended Operating Viscosity Range cSt (SUS)	Maximum Continuous cSt (SUS)	Maximum Viscosity at Startup cSt (SUS)	Minimum Viscosity @ Max. Intermittent Temperature of 93°C (200°F) cSt (SUS)	Minimum Intermittent cSt (SUS)
Use antiwear hydraulic oil, or automotive type crankcase oil (designations SC, SD, SE, or SF) per SAE J183 FEB80	16 to 40 (80 to 188)	430 (1192)	2100 (9720)	10 (59)	6 (46)

For more information, see Eaton publication 579. For operation on other alternative or environmentally friendly fluids, please contact your Eaton Representative.

Fluid Cleanliness

The 420 Series pumps are rated in anti-wear petroleum fluids with a contamination level of 20/18/13 (Eaton) or ISO 18/13. Operation in fluids with levels more contaminated than this is not recommended. Fluids other than petroleum, severe service cycles, or temperature extremes are cause for adjustment of these codes. Please contact

your Eaton Representative for specific duty cycle recommendation.

Eaton 420 Series pumps, as with any variable displacement piston pumps, will operate with apparent satisfaction in fluids up to the rating specified here. Experience has shown, however, that pump and hydraulic system life is not optimized with high fluid contamination levels (high ISO cleanliness codes).

Proper fluid condition is essential for long and satisfactory life of hydraulic components and systems. Hydraulic fluid must have the correct balance of cleanliness, materials, and additives for protection against wear of components, elevated viscosity and inclusion of air.

Essential information on the correct methods for treating hydraulic fluid is included in

Eaton publication 561 – "Eaton Guide to Systemic Contamination Control" – available from your local Eaton distributor. In this publication, filtration and cleanliness levels for extending the life of axial piston pumps and other system components are listed. Included is an excellent discussion of the selection of products needed to control fluid condition.

Installation and Start-up

Warning: Care should be taken that mechanical and hydraulic resonances are avoided in the application of the pump. Such resonances can seriously compromise the life and/or safe operation of the pump.

Drive Data

Mounting attitude can be either horizontal or vertical, using the appropriate case drain ports to ensure that the case remains full of fluid at all times. Consult your local Eaton Representative if a different arrangement is required.

In those cases where geometric tolerances of mounting are critical, or where specific tolerance ranges are required and not specified, consult Eaton Engineering for specific limits.

Direction of shaft rotation, viewed from the prime mover end, must be as indicated in the model designation on the pump – either right hand (clockwise) or left hand (counterclockwise).

Direct coaxial drive through a flexible coupling is recommended. If drives imposing radial shaft loads are considered, please consult your Eaton Representative.

Start-up Procedure

Make sure the reservoir and circuit are clean and free of dirt/debris prior to filling with hydraulic fluid.

Fill the reservoir with filtered oil and fill to a level sufficient enough to prevent vortexing at the suction connection to pump inlet. It is good practice to clean the system by flushing and filtering, using an external slave pump.

Caution: Before the pump is started, fill the case through the uppermost drain port with hydraulic fluid of the type to be used. The case drain line must be connected directly to the reservoir and must terminate below the oil level.

Once the pump is started, it should prime within a few seconds. If the pump does not prime, check to make sure that there are no restrictions between the reservoir and the inlet to the pump, that the pump is being rotated in the proper direction, and that there are no air leaks in the inlet line and connections. Also check to make sure that trapped air can escape at the pump outlet.

After the pump is primed, tighten the loose outlet connections, then operate for five to ten minutes (unloaded) to remove all trapped air from the circuit.

If the reservoir has a sight gage, make sure the fluid is clear – not milky.

Notes

Eaton
14615 Lone Oak Road
Eden Prairie, MN 55344
USA
Tel: 952 937-9800
Fax: 952 974-7722
www.hydraulics.eaton.com

Eaton
20 Rosamond Road
Footscray
Victoria 3011
Australia
Tel: (61) 3 9319 8222
Fax: (61) 3 9318 5714

Eaton
Dr.-Reckeweg-Str. 1
D-76532 Baden-Baden
Germany
Tel: (49) 7221 682-0
Fax: (49) 7221 682-788



Hydraulics

© 2004 Eaton Corporation
All rights reserved
Printed in USA
Document No. E-PUPI-TM002-E
January 2004